

# The Harman Kardon Models T55C and T60C

Manual No. 75A

## FLOATING SUSPENSION AUTO-LIFT TURNTABLE

# Technical Manual



Model T60C



Model T55C

**harman/kardon**

240 CROSSWAYS PARK WEST, WOODBURY, N.Y. 11797  
1112-H15275A9 P-08845 1650 PRINTED IN JAPAN

**SPECIFICATIONS**

<b>Wow &amp; Flutter (WRMS)</b>	0.035%
<b>Rumble (DIN-B WTD)</b>	-68dB, DIN 45544 record reference
<b>Pitch Adjustable Range</b>	±3%
<b>Tonearm</b>	
Effective Tonearm Mass	8g (plus the mass of the cartridge used)
Stylus Overhang	18 mm
Offset Angle	25.5°
Effective Length	216 mm
Tracking Error	±2 degrees
Phono Capacitance	100/200/300pF
Tracking Force	0 ~ 3 grams

<b>Acceptable Weight of Cartridge</b>	3 ~ 8g
<b>Dimensions (W x H x D)</b>	17-1/2" x 5-3/4" x 15-1/8" (443 x 145 x 384mm)
<b>Weight</b>	
T55C	16 lbs. 1 oz. (7.3kg)
T60C	17 lbs. 10 oz. (8 kg)
<b>Power Supply</b>	
U.S.A. and Canada models	AC120V, 60Hz
General model	AC110-120V/220-240V, 50/60Hz
<b>Power Consumption</b>	
U.S.A. and Canada models	8W
General model	10W

Specifications and components subject to change without notice.  
Overall performance will be maintained or improved.

**LEAKAGE TEST (FOR SERVICE ENGINEERS IN THE U.S.A.)**

Before returning the unit to the user, perform the following safety checks:

1. Inspect all lead dress to make certain that leads are not pinched or that hardware is not lodged between the chassis and other metal parts in the unit.
2. Be sure that any protective devices such as nonmetallic control knobs, insulating fishpapers, cabinet backs, adjustment and compartment covers or shields, isolation resistor-capacity networks, mechanical insulators, etc. which were removed for servicing are properly reinstalled.
3. Be sure that no shock hazard exists; check for leakage current using Simpson Model 229 Leakage Tester, standard equipment item No. 21641, RCA Model WT540A or use alternate method as follows:

Plug the power cord directly into a 120-volt AC receptacle (do not use an Isolation Transformer for this test). Using two clip leads, connect a 1500 Ohm, 10-watt resistor paralleled by a 0.15μF capacitor, in series with all exposed metal cabinet parts and a known earth ground, such as a water pipe or conduit. Use a VTVM or VOM with 1000 Ohms per volt, or higher, sensitivity to measure the AC voltage drop across the resistor. (See Diagram.) Move the resistor connection to each exposed metal part having a return path to the chassis (antenna, metal, cabinet, screw heads, knobs and control shafts, escutcheon, etc.) and measure the AC voltage drop across the resistor. (This test should be performed with the power switch in both the On and Off positions.)

A reading of 0.35 volt RMS or more is excessive and indicates a potential shock hazard which must be corrected before returning the unit to the owner.

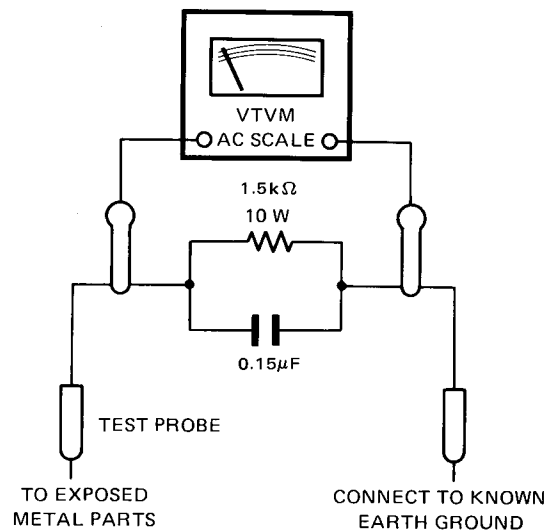
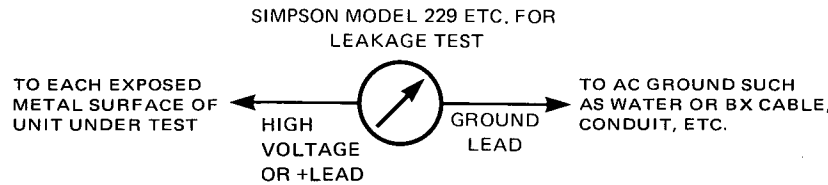

T55C/T60

## DISASSEMBLY PROCEDURES (REFER TO PAGES 7, 8 AND 14.)

**NOTE:** Before disassembling the unit, remove the platter, platter mat, counterweight and headshell with cartridge, and securely tie the arm to the armrest with string, etc. Then gently turn the unit upside down and place it on cloths, etc. piled up on both sides to protect the arm and cabinet from damage.

### ① CABINET BOTTOM ASSEMBLY (102) REMOVAL

Remove screw **A** and 10 screws **B** and remove the Cabinet Bottom Assembly (102).

\*Toothed washer is attached to the screw **A**

### ② FRONT PANEL ASSEMBLY (103) REMOVAL

1. Remove the Cabinet Bottom Assembly (102). (Refer to step ①.)

2. Remove 7 screws **C** and remove the Bracket (188) with PCB-3, 6, 7 and 8 by pulling the Front Panel Assembly slightly forward then remove the Front Panel Assembly (103).

### ③ PICK-UP ASSEMBLY (129) REMOVAL

1. Remove the Cabinet Bottom Assembly (102). (Refer to step ①.)

2. Unsolder the lead wires connected to the Solenoid for lifter from Photo Transistor P.C. Board (PCB-5), and unsolder the lead wires connected to the Tonearm from Relay P.C. Board (PCB-10).

3. Loosen screw **D** and remove the Lever Assembly (105).

4. Remove 3 screws **E** and remove the Pick-Up Assembly (129).

### ④ CHASSIS ASSEMBLY (104) REMOVAL

1. Remove the Pick-Up Assembly (129). (Refer to step ③.)

2. Remove 5 screws **F** and remove the Relay P.C. Board (PCB-10), LED P.C. Board (PCB-4), Photo Transistor P.C. Board (PCB-5) and Power Switch (SW1).

3. Unsolder the lead wire connected to the Shaft (281) and remove screw **G** and then remove the Lug Terminal (LUG4, 5, 6) with lead wires.

4. Remove 3 nuts **H** and remove the Chassis Assembly (104) by turning the central screws (210) of nuts **H** clockwise.

### ⑤ MOTOR (MO1) REMOVAL

1. Remove the Cabinet Bottom Assembly (102). (Refer to step ①.)

2. Unsolder the lead wires connected to the Motor (MO1).

3. Remove 3 screws **I** and remove the motor (MO1).

### ⑥ POWER TRANSFORMER (T1) REMOVAL

1. Remove the Cabinet Bottom Assembly (102). (Refer to step ①.)

2. Unsolder the lead wires connected to the Power Transformer (T1).

3. Remove 2 screws **J** and remove the Power Transformer (T1).

## POWER CORD REPLACEMENT (FOR SERVICE ENGINEERS OTHER THAN NORTH AMERICA)

In order to prevent fire or shock hazard when replacing the power cord, follow the procedure below to replace the parts with the standard supply parts.

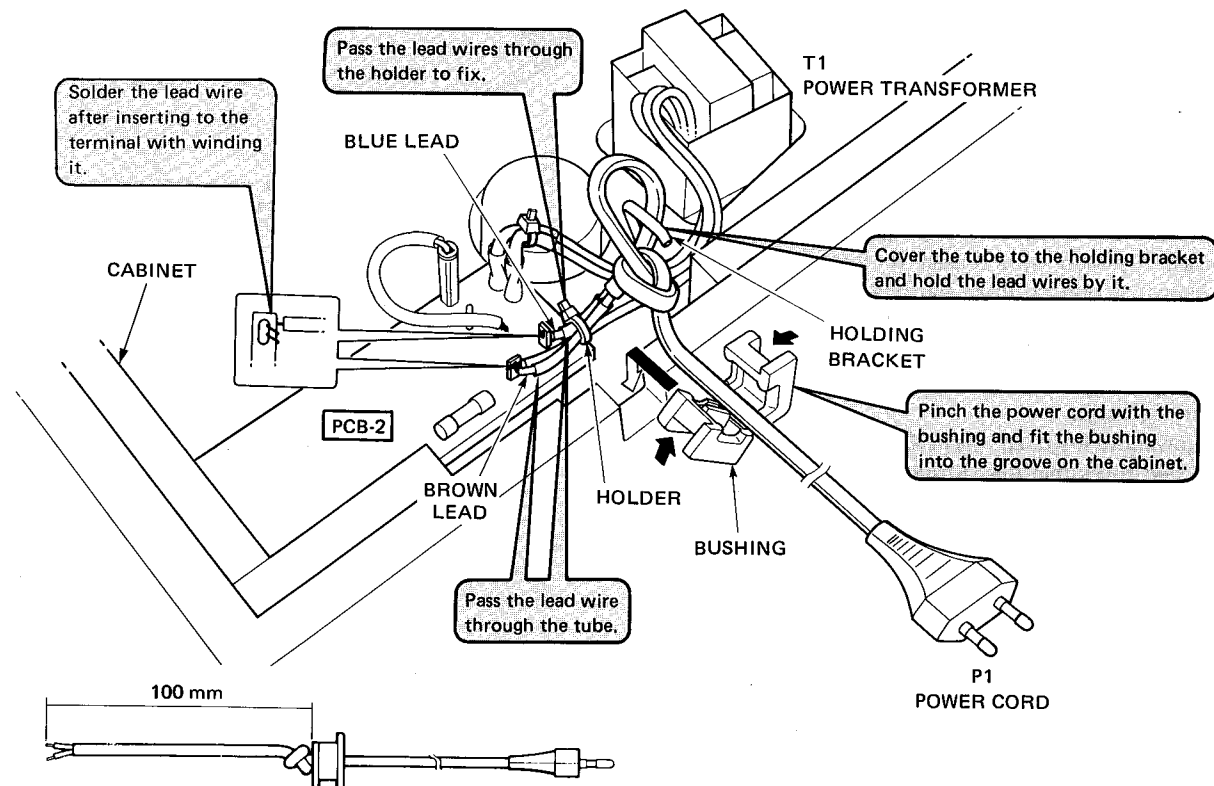

## CARTRIDGE REPLACEMENT INSTRUCTION

Only use cartridges in the headshell provided. Be sure to use a cartridge weighting 3 to 8 grams.

1. Release the tonearm clamp and lift the tonearm gently.
2. Loosen the headshell clamp and gently pull the headshell with cartridge. (See Fig. A.)
3. Disconnect the 4 leads from cartridge pins using a tweezers and then loosen the retaining screws so that the cartridge comes out.
4. Replace the leads onto the new cartridge. Refer to Fig. B for correct placement of leads.
5. When all leads are connected properly, install cartridge to the headshell as shown in the Fig. B.
6. Temporarily tighten the retaining screw to hold the cartridge.
7. Insert the headshell with the cartridge fully into the tonearm and then tighten the headshell clamp.

When cartridge is replaced with new one, it is necessary to adjust the Overhang and Tracking angle.

### ● Overhang Adjustment

1. Place the accessory tracking angle gauge on the center spindle and raise the flap.
2. Be sure to remove the stylus guard when adjusting the overhang.
3. Move the tonearm directly over the center spindle. Line up the raised flap on the gauge with the center spindle and the tonearm base. Gently move the cartridge backward or forward in the headshell so that the stylus tip lines up with the corner of the flap.

### ● Tracking Angle Adjustment

1. Check to be sure that the overhang adjustment has been completed.
2. Now move the tracking angle gauge until it is in the same position with respect to the tonearm as that shown in Fig. D. Place the stylus over the tracking angle setting point with keeping stylus guard attached.
3. Without changing the stylus position, turn the cartridge so that its front edge is parallel with the lines on the gauge.
4. Now move it so that it is in the position shown in Fig. E and check that the cartridge is still parallel with the parallel lines as it was in step 3 above. If it is not parallel, then repeat steps 3 and 4 alternately until the cartridge is parallel in both cases.
5. When the above adjustment is completed, then tighten the screws that attach the cartridge to the headshell fully.

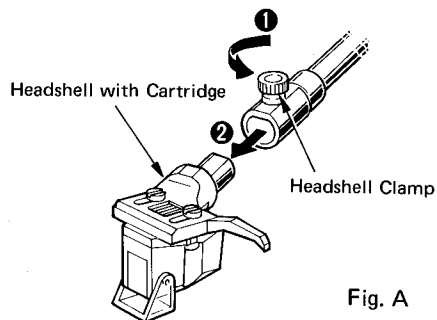

Fig. A

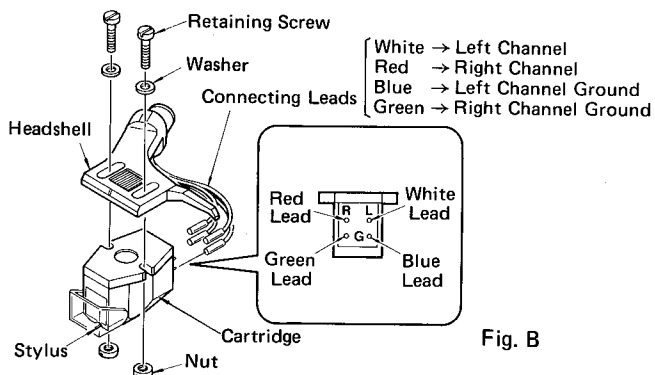

Fig. B

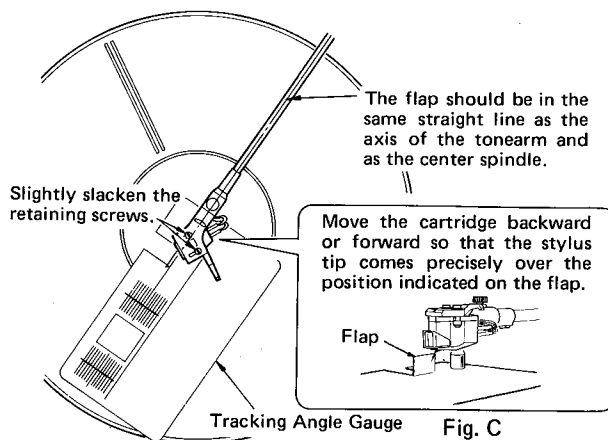

Fig. C

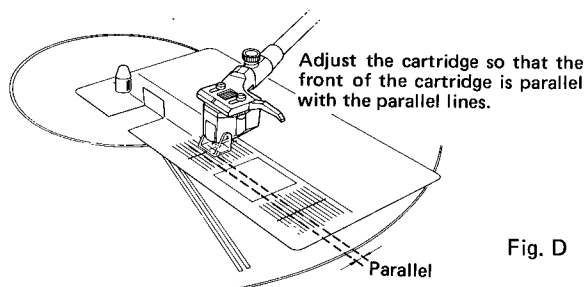

Fig. D

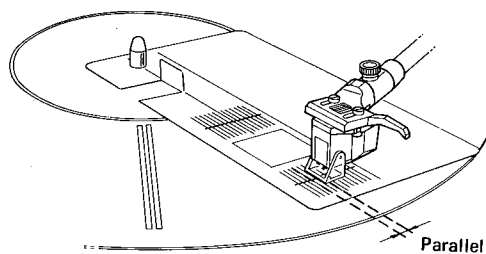
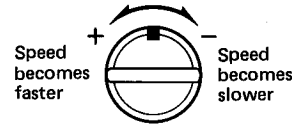

Fig. E

## ALIGNMENT PROCEDURES

### ■ SPEED CONTROL

1. Place a disc on the platter mat and then the disc stabilizer with stroboscope on the disc.
2. Set the speed selector to 33 or 45 position in accordance with the required disc speed.
3. Turn the quartz lock button OFF to release the quartz lock, then adjust the disc speed by turning the speed control knob, with observing the striped markings on the disc stabilizer with stroboscope under fluorescent light.



SPEED CONTROL

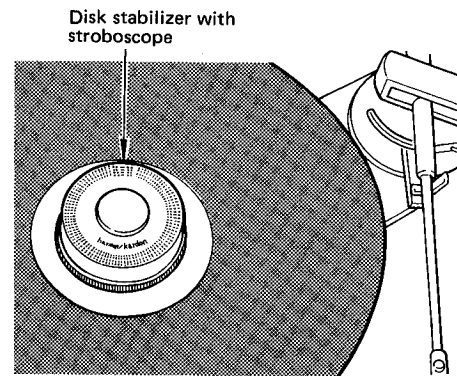

### ■ CAPACITANCE TRIM

The capacitance trim is a capacitance selector switch that enables your cartridge to deliver its optimum performance. Each cartridge had its own characteristic capacitance, and the output leads used to connect the cartridge to the amplifier or receiver also have their own capacitance. Only when these two capacitances are at their optimum values can the cartridge transfer its output and retain its optimum frequency response to the amplifier.

Cartridge capacity	Trim position
Less than 300pF	normal
300 to 400pF	+100pf
Over 400pF	+200pf

- Please read the owner's manual of the cartridge and adjust the trim position accordingly.

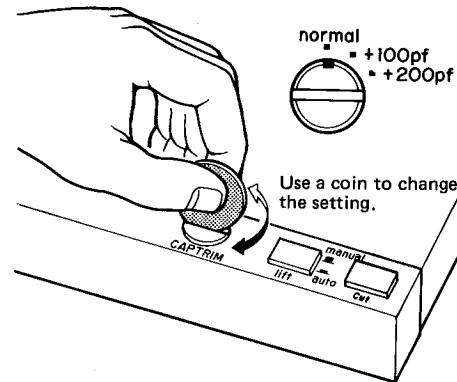

### ■ SUSPENSION ADJUSTMENT

#### \*Conditions

1. Make sure to install the platter, rubber platter mat and disc stabilizer.  
(It is not necessary for you to hang the drive belt between the platter and motor pulley.)
2. Install the cartridge and counter weight to the tonearm. (Set the tracking force to about 2g.)  
Be sure to place the tonearm on the armrest.
3. Be sure that the power is off.

#### ● ADJUSTMENT

1. Adjust so that the space between platter and surface of cabinet is 4 mm ± 0.2 mm by turning screws ① to ③ in Fig. 1.  
(Turning these screws clockwise moves the platter down and turning them counterclockwise moves it up.)
2. After adjustments, confirm that the platter moves up and down in the well-balanced condition even if the platter is pressed down in the cabinet.

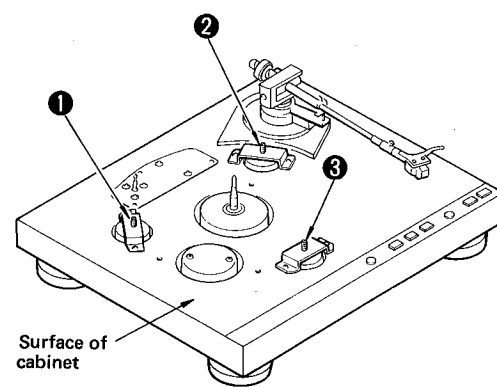

Fig. 1

### ■ DISC END DETECTION POSITION ADJUSTMENT

#### \*Conditions

Be sure not to hang the drive belt between platter and motor pulley.

Quartz Lock Switch ..... On  
Lift Switch ..... Auto

#### ● LP POSITION ADJUSTMENT

1. Set the speed selector to 33 r.p.m.
2. Lower the cueing lever.  
(Arm Lifter is set to the low position.)
3. Adjust by adjustment screw attached to the lower part of the tonearm so that the stylus of cartridge detects the disc end position between 111.94 mm ~ 107.2 mm from the center of spindle.

#### ● EP POSITION ADJUSTMENT

1. Set the speed selector to 45 r.p.m.
2. Lower the cueing lever.  
(Arm Lifter is set to the low position.)
3. Adjust by adjustment screw attached to the lower part of the tonearm so that the stylus of cartridge detects the disc end position between 102.74 mm ~ 98.4 mm from the center of spindle.

#### NOTE:

1. Turning the adjustment screw clockwise makes a fast detection of the disc end position, and turning it counterclockwise makes slow detection.
2. If it is not within the rate, assumedly, it result from the attached position of lever assembly.  
Try to change the attaching position by loosening the fixed screw.
3. When the disc end position is detected, the motor revolution stops, and arm lifter is raised.  
If you are going to start it again, place the tonearm on armrest once.

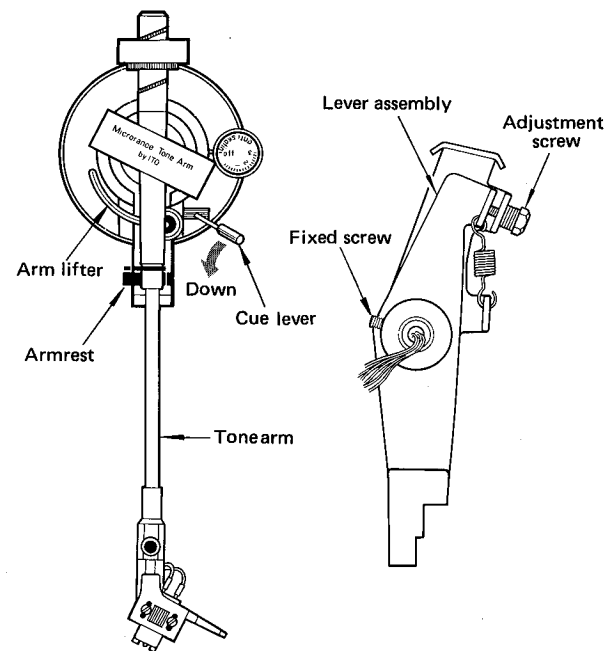

### ■ MOTOR R.P.M. ADJUSTMENT

#### \*Instrument

Low Range Tachometer

#### \*Condition

1. Be sure that the drive belt between platter and motor pulley is hung.
2. Flip the cue lever forward to lift the tonearm up.

#### ● QUARTZ LOCK ADJUSTMENT

1. Set the speed selector to 33 r.p.m., and set the quartz lock switch to ON.
2. Move tonearm horizontally as to be level with the platter, and rotate the platter.
3. Measure the motor speed by a low range tachometer.
4. Replace the motor pulley when the motor speed is not within the specified range.
5. Check the motor speed in condition that the speed selector is set to 45 r.p.m.

#### ● QUARTZ LOCK OFF ADJUSTMENT

1. Set the speed selector to 33 r.p.m. and set the quartz lock switch to OFF, then set the speed control knob to the center position.
2. Move tonearm horizontally as to be level with the platter, and rotate the platter.
3. With the platter turning, adjust VR101 so that the motor speed rating is within 33-1/3 r.p.m. ±1%, and then adjust VR103 so that the motor speed rating is within 33-1/3 r.p.m.
4. Set the speed selector to 45 r.p.m.
5. With the platter turning, adjust VR102 so that the motor speed rating is within 45 r.p.m. ±1%, and then adjust VR104 so that the motor speed rating is within 45 r.p.m.
6. After all of these adjustment are over, make sure to confirm that each motor speed make a change more than ±3% with using speed control knob.

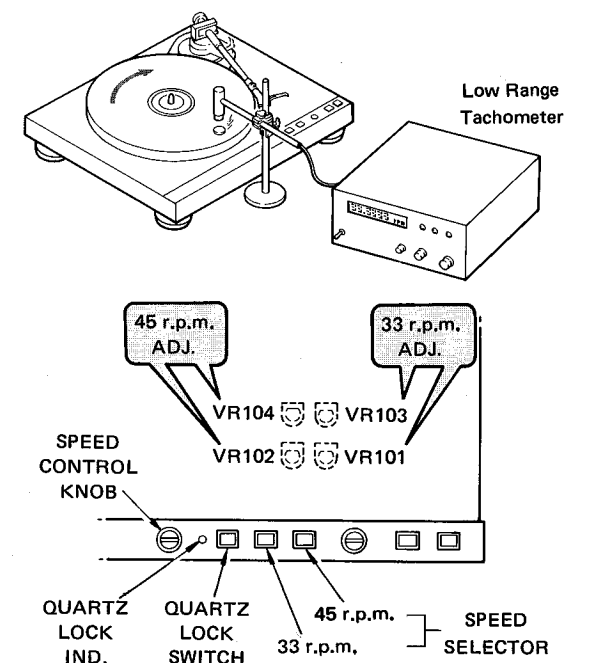

## ALIGNMENT PROCEDURES

### ■ SPEED CONTROL

1. Place a disc on the platter mat and then the disc stabilizer with stroboscope on the disc.
2. Set the speed selector to 33 or 45 position in accordance with the required disc speed.
3. Turn the quartz lock button OFF to release the quartz lock, then adjust the disc speed by turning the speed control knob, with observing the striped markings on the disc stabilizer with stroboscope under fluorescent light.

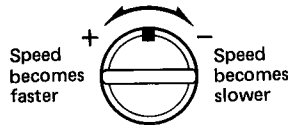

SPEED CONTROL

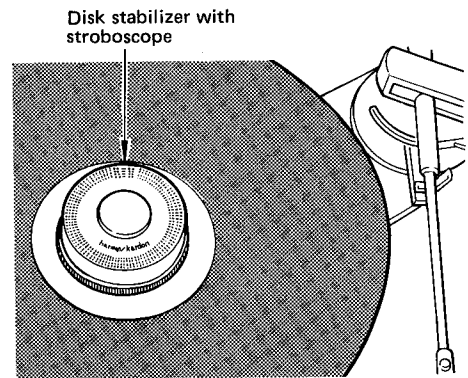

### ■ CAPACITANCE TRIM

The capacitance trim is a capacitance selector switch that enables your cartridge to deliver its optimum performance. Each cartridge had its own characteristic capacitance, and the output leads used to connect the cartridge to the amplifier or receiver also have their own capacitance. Only when these two capacitances are at their optimum values can the cartridge transfer its output and retain its optimum frequency response to the amplifier.

Cartridge capacity	Trim position
Less than 300pF	normal
300 to 400pF	+100pf
Over 400pF	+200pf

- Please read the owner's manual of the cartridge and adjust the trim position accordingly.

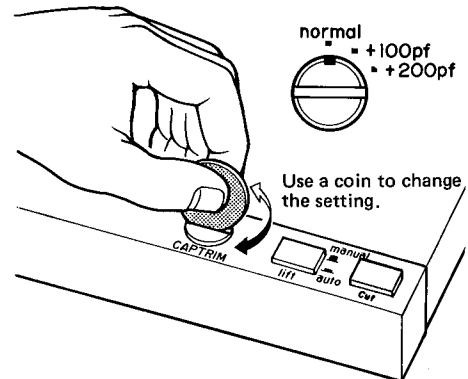

### ■ SUSPENSION ADJUSTMENT

#### \*Conditions

1. Make sure to install the platter, rubber platter mat and disc stabilizer.  
(It is not necessary for you to hang the drive belt between the platter and motor pulley.)
2. Install the cartridge and counter weight to the tonearm. (Set the tracking force to about 2g.)  
Be sure to place the tonearm on the armrest.
3. Be sure that the power is off.

#### ● ADJUSTMENT

1. Adjust so that the space between platter and surface of cabinet is 4 mm  $\pm$  0.2 mm by turning screws ① to ③ in Fig. 1.  
(Turning these screws clockwise moves the platter down and turning them counterclockwise moves it up.)
2. After adjustments, confirm that the platter moves up and down in the well-balanced condition even if the platter is pressed down in the cabinet.

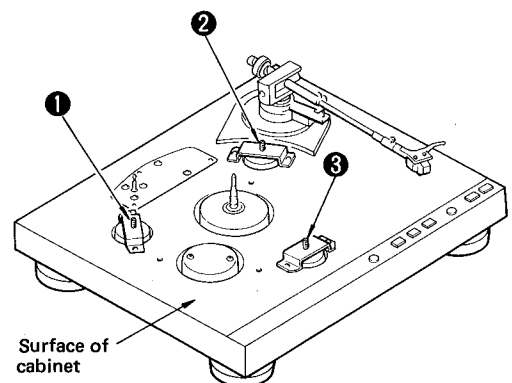

Fig. 1

■ DISC END DETECTION POSITION ADJUSTMENT

\*Conditions

Be sure not to hang the drive belt between platter and motor pulley.

Quartz Lock Switch ..... On  
Lift Switch ..... Auto

● LP POSITION ADJUSTMENT

1. Set the speed selector to 33 r.p.m.
2. Lower the cueing lever.  
(Arm Lifter is set to the low position.)
3. Adjust by adjustment screw attached to the lower part of the tonearm so that the stylus of cartridge detects the disc end position between 111.94 mm ~ 107.2 mm from the center of spindle.

● EP POSITION ADJUSTMENT

1. Set the speed selector to 45 r.p.m.
2. Lower the cueing lever.  
(Arm Lifter is set to the low position.)
3. Adjust by adjustment screw attached to the lower part of the tonearm so that the stylus of cartridge detects the disc end position between 102.74 mm ~ 98.4 mm from the center of spindle.

NOTE:

1. Turning the adjustment screw clockwise makes a fast detection of the disc end position, and turning it counterclockwise makes slow detection.
2. If it is not within the rate, assumedly, it result from the attached position of lever assembly.  
Try to change the attaching position by loosing the fixed screw.
3. When the disc end position is detected, the motor revolution stops, and arm lifter is raised.  
If you are going to start it again, place the tonearm on armrest once.

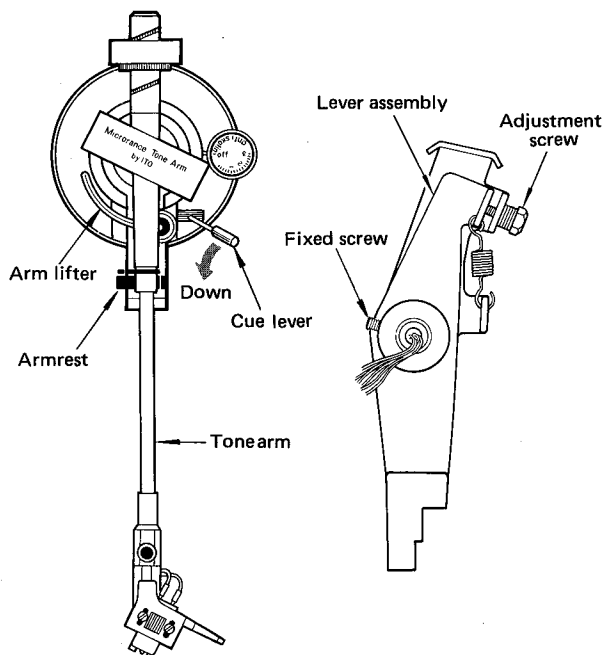

Fig. 1

■ MOTOR R.P.M. ADJUSTMENT

\*Instrument

Low Range Tachometer

\*Condition

1. Be sure that the drive belt between platter and motor pulley is hung.
2. Flip the cue lever forward to lift the tonearm up.

● QUARTZ LOCK ADJUSTMENT

1. Set the speed selector to 33 r.p.m., and set the quartz lock switch to ON.
2. Move tonearm horizontally as to be level with the platter, and rotate the platter.
3. Measure the motor speed by a low range tachometer.
4. Replace the motor pulley when the motor speed is not within the specified range.
5. Check the motor speed in condition that the speed selector is set to 45 r.p.m.

● QUARTZ LOCK OFF ADJUSTMENT

1. Set the speed selector to 33 r.p.m. and set the quartz lock switch to OFF, then set the speed control knob to the center position.
2. Move tonearm horizontally as to be level with the platter, and rotate the platter.
3. With the platter turning, adjust VR101 so that the motor speed rating is within 33-1/3 r.p.m. ±1%, and then adjust VR103 so that the motor speed rating is within 33-1/3 r.p.m.
4. Set the speed selector to 45 r.p.m.
5. With the platter turning, adjust VR102 so that the motor speed rating is within 45 r.p.m. ±1%, and then adjust VR104 so that the motor speed rating is within 45 r.p.m.
6. After all of these adjustment are over, make sure to confirm that each motor speed make a change more than ±3% with using speed control knob.

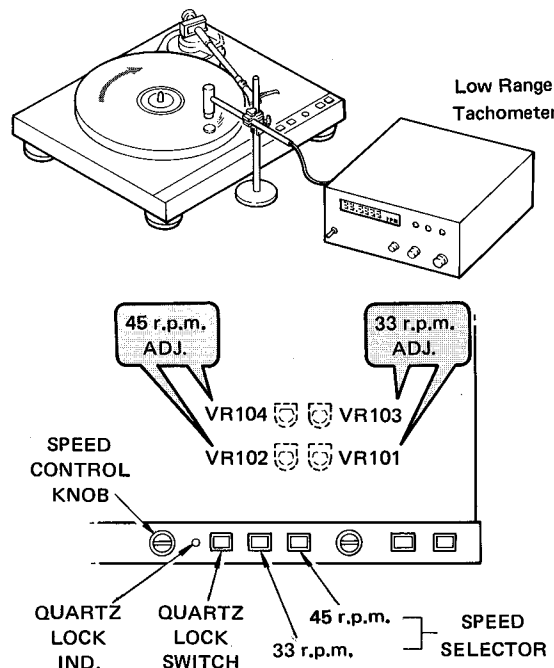

GENERAL UNIT EXPLODED VIEW

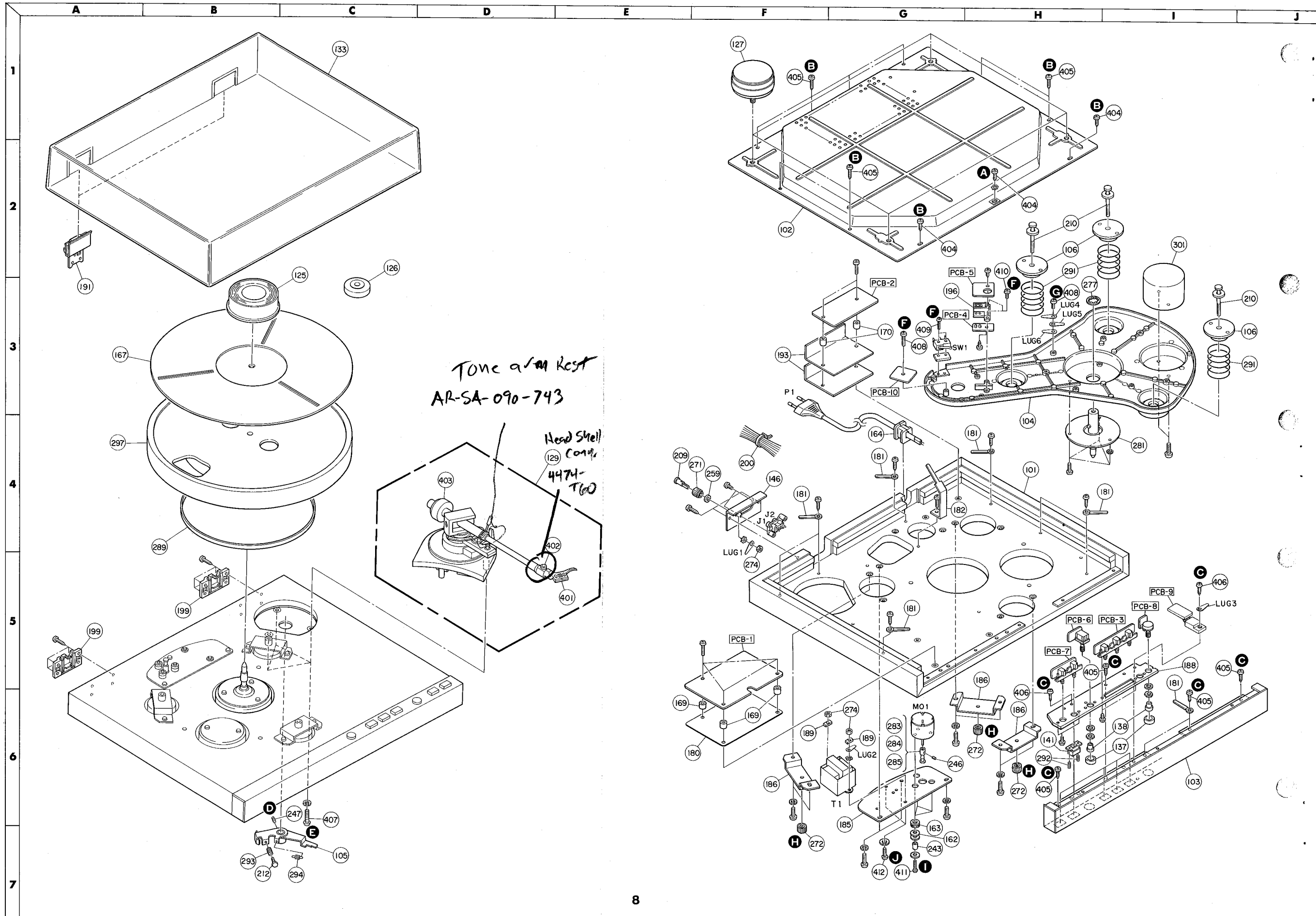



GENERAL UNIT EXPLODED VIEW

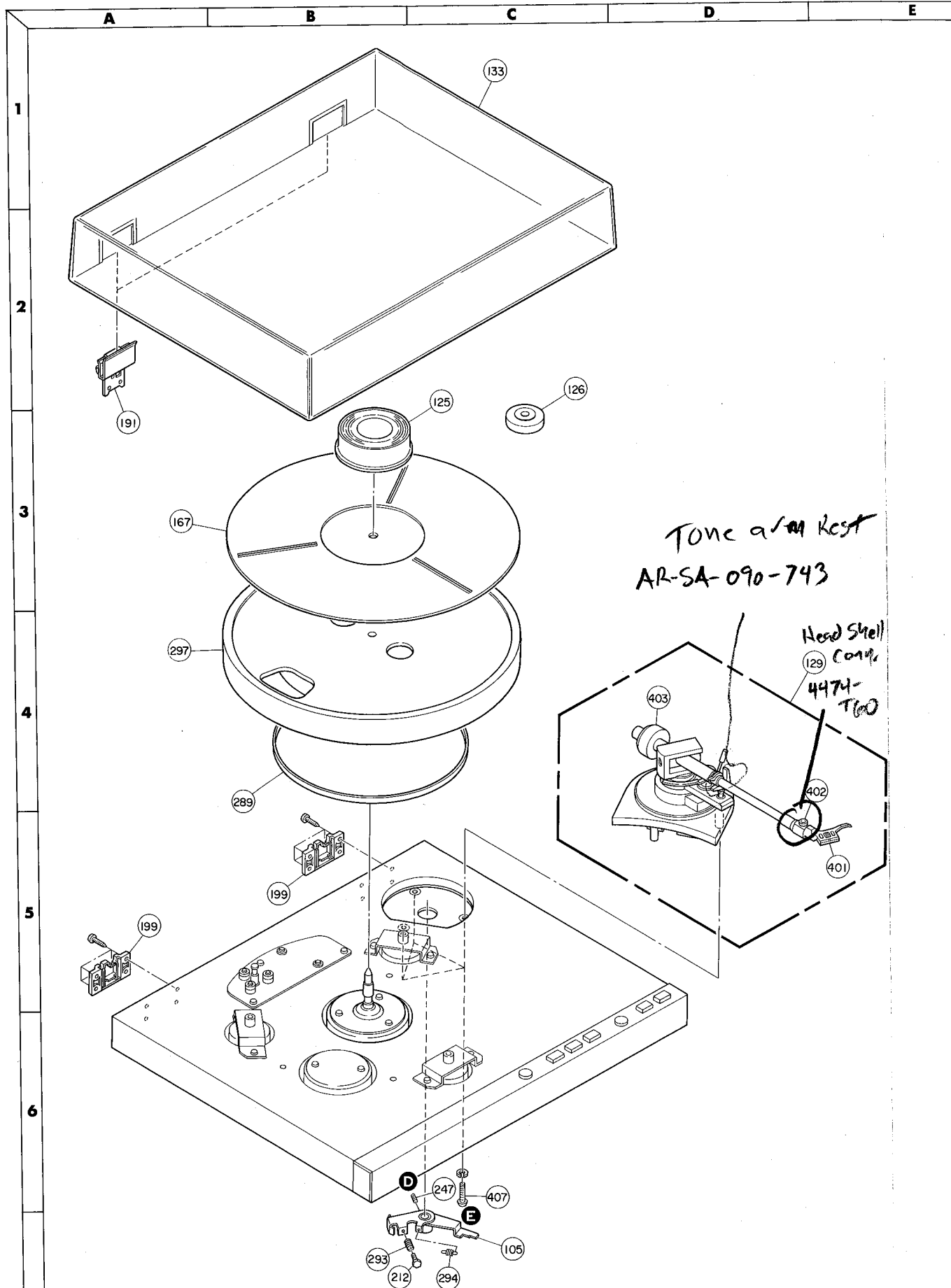

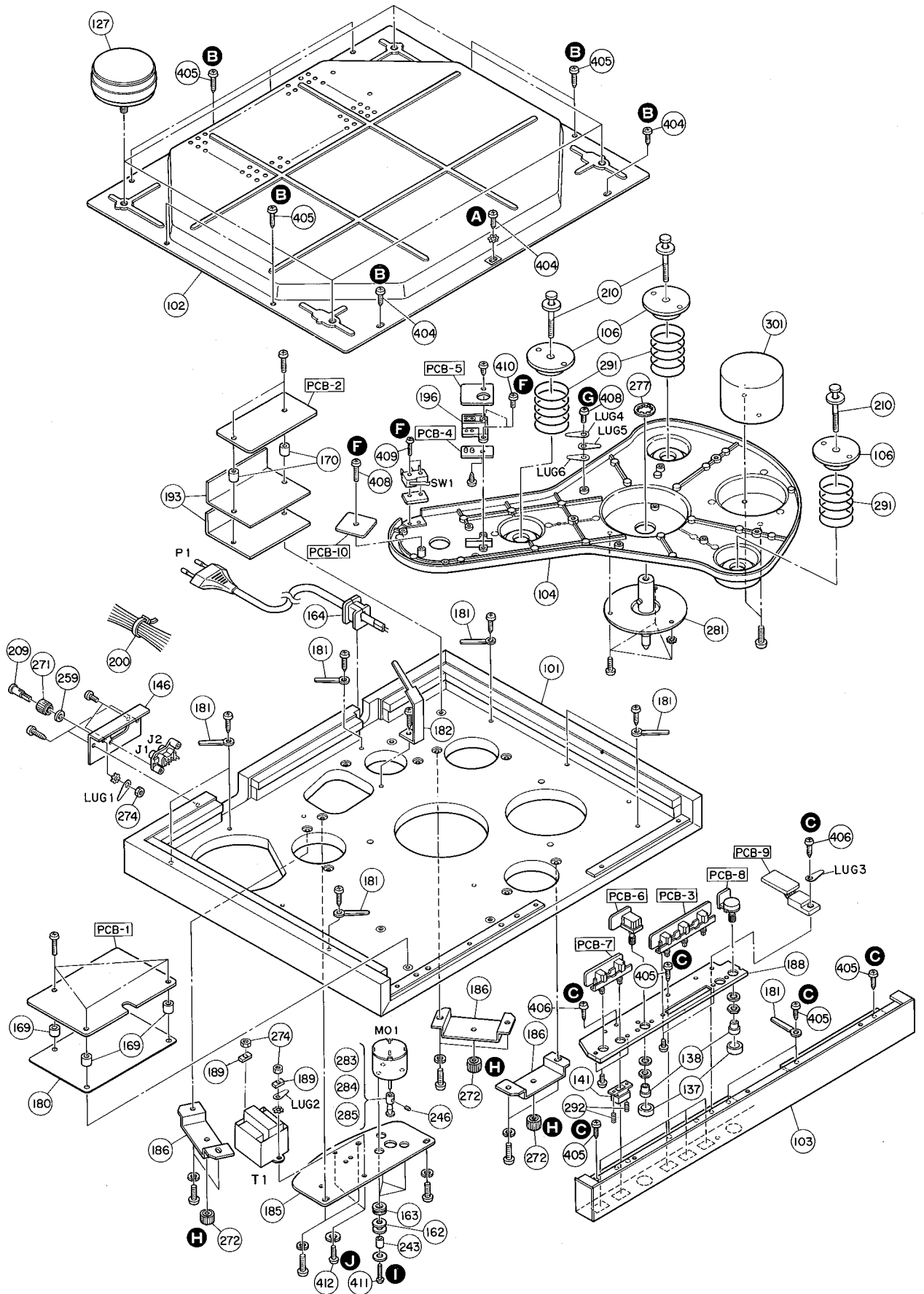

## GENERAL UNIT PARTS LIST

Ref. No.	Part No.	Description
101	A415-T55CA	Cabinet Assembly (for U.S.A. & Canada models of T55C)
"	A415-T55CB	Cabinet Assembly (for General model of T55C)
"	A415-T60CA	Cabinet Assembly (for T60C)
102	A424-T55CA	Cabinet Bottom Assembly (for U.S.A. & General models)
"	A424-T55CB	Cabinet Bottom Assembly (for Canada model)
103	A443-T55CA	Front Panel Assembly (for T55C)
"	A443-T60CA	Front Panel Assembly (for T60C)
104	B211-T55CA	Chassis Assembly (for U.S.A. & General models of T55C)
"	B211-T55CB	Chassis Assembly (for Canada model of T55C)
"	B211-T60A	Chassis Assembly (for T60C)
105	B672-T55CA	Lever Assembly
106	B219-T55CA	Spring Holder Assembly
125	1161-00101	Disc Stabilizer
126	1362-7007	45 R.P.M. Adaptor
127	1319-0247	Foot (for T55C)
"	1319-0147	Foot (for T60C)
129	1371-716	Pick-Up Assembly (Includes: SO701 Solenoid) (for T55C)
"	1371-715	Pick-Up Assembly (Includes: SO701 Solenoid) (for T60C)
133	1472-01301	Dust Cover
137	1634-03601	Knob, Capacitance Trim, Speed Control
138	1355-7040	Knob Base, Capacitance Trim, Speed Control
141	1660-00201	Push Button, Quartz Lock, 33/45 Speed Selector, Lift, Cut
146	1724-02601	Indication Plate
162	2111-1386	Felt
163	2114-71262	Bushing, Motor
164	2114-71264	Bushing, Power Cord (for U.S.A. & Canada models)
"	2114-71270	Bushing, Power Cord (for General model)
167	2115-00101	Platter Mat
169	2132-01406	Spacer
170	2132-7016	Spacer
180	2216-7134	Shield Plate
181	2218-7001	Holding Bracket
182	2218-7016	Holding Bracket
185	2219-7864	Bracket
186	2219-7865	Bracket
188	2219-7996	Bracket
189	2219-7359	Bracket
191	2221-7120	Hinge
193	2224-7074	Insulator
196	2240-7190	Holder
199	2240-7194	Holder
200	2240-7120	Holder
209	2310-7015	Special Screw
210	2310-7020	Special Screw
212	2316-300829	Hexagon Screw
243	2363-501719	Collar, Motor
246	2371-200429	Setting Screw, Motor Pulley
247	2374-30042D9	Setting Screw, Lever
259	2410-7005	Special Washer
271	2440-7011	Special Nut
272	2440-64	Special Nut
274	2446-30229	Hexagon Nut
277	2467-1402	Stopper
281	2601-7108	Shaft
283	2618-7002	Motor Pulley (*)
284	2618-7003	Motor Pulley (*)
285	2618-7004	Motor Pulley (*)
289	2642-02701	Drive Belt
291	2651-2101714	Spring (for T55C)
"	2651-2101701	Spring (for T60C)
292	2651-2101702	Spring
293	2651-2101116	Spring
294	2651-110331	Spring
297	2665-7111	Platter (for T55C)
"	2665-715	platter (for T60C)
301	2691-7002	Balancer (for T55C)
"	2691-7001	Balancer (for T60C)

Ref. No.	Part No.	Description
401	852366S	Headshell
402	852366A	Headshell Clamp
403	852366W	Counterweight
404	2347-300842	Self-Tapping Screw (+)
405	2347-301241	Self-Tapping Screw (+)
406	2347-301022	Self-Tapping Screw (+)
407	2327-301229	Screw (+)
408	2347-300822	Self-Tapping Screw (+)
409	2327-231029	Screw (+)
410	2327-300629	Screw (+)
411	2327-251249	Screw (+)
412	2327-301249	Screw (+)

(\*) There are three kind of motor pulley, these are reference No. 283, 284 and 285.

Replace the motor pulley accordance with QUARTZ LOCK ADJUSTMENT of MOTOR R.P.M. ADJUSTMENT on page 6.

## ELECTRICAL PARTS LIST

Ref. No.	Part No.	Description
<b>CHASSIS MISCELLANEOUS</b>		
△ P1	4161-0787	Power Cord (for U.S.A. & Canada models)
△ "	4161-7256	Power Cord (for General model)
△ T1	5584-701415	Power Transformer (for U.S.A. & Canada models)
△ "	5584-701412	Power Transformer (for General model)
MO1	4311-1A154	DC Motor
△ SW1	4431-A017128	Push Switch, Power
J1/2	4482-7121	2-Pin Jack, Output
J101	4163-70865	Connector with Lead Wire, 7-Pin
LUG1, 2, 3, 4, 5, 6	4211-5005	Lug Terminal
<b>PCB-1 MOTOR CONTROL P.C. BOARD</b>		
<b>RESISTORS</b>		
R109, 114	5174-683381	68kΩ, ±1%, 1/4W, Metal
<b>CONTROLS</b>		
VR101, 102	5101-1041926	100kΩ, Motor R.P.M. Adjustment
VR103, 104	5101-1031926	10kΩ, Motor R.P.M. Adjustment
<b>CAPACITORS</b>		
C101, 107	5345-105F041	1μF, ±20%, 50V, Electrolytic
C102, 113, 203	5345-475F041	4.7μF, ±20%, 50V, Electrolytic
C104	5345-476B041	47μF, ±20%, 10V, Electrolytic
C108	5345-225F041	2.2μF, ±20%, 50V, Electrolytic
C111	5345-224F0952	0.22μF, ±20%, 50V, Electrolytic
C112, 117	5345-107C041	100μF, ±20%, 16V, Electrolytic
C115	5345-105F0952	1μF, ±20%, 50V, Electrolytic
C116	5345-226C041	22μF, ±20%, 16V, Electrolytic
C118	5345-476C0952	47μF, ±20%, 16V, Electrolytic
C201	5345-106F041	10μF, ±20%, 50V, Electrolytic
C202	5345-106C041	10μF, ±20%, 16V, Electrolytic
<b>INTEGRATED CIRCUIT</b>		
IC101	5654-TC9142P	TC9142P
IC102	5652-CX-065B	CX-065B
<b>TRANSISTORS</b>		
Q101, 102, 103, 104, 105, 202, 204, 205	5613-2603(E)	2SC2603(E) or 2SC2603(F)
Q201	5613-2603(F)	2SC2603(F)
Q203	5613-2236(Y)	2SC2236(Y) or 2SC2236(O)
<b>DIODES</b>		
D101	5635-RD5R1EB1	Zener, RD5.1EB1
D201	5636-1S2471	1S2471
D202	5632-1SR35-10	1SR35-10

Ref. No.	Part No.	Description
X101 SCR201 P101	<b>MISCELLANEOUS</b> 5691-02073620 5661-03P05M 4443-074116	Crystal, Osc. Silicon Controlled Rectifier, 03P05M Connector, 7-Pin
<b>PCB-2 POWER SUPPLY P.C. BOARD</b>		
R1	<b>RESISTOR</b> 5176-221582	220 $\Omega$ , $\pm$ 5%, 1/2W, Metal
C3 C4, 5, 6 C7, 8	<b>CAPACITORS</b> 5345-475F041 5345-227D041 5345-106D041	4.7 $\mu$ F, $\pm$ 20%, 50V, Electrolytic 220 $\mu$ F, $\pm$ 20%, 25V, Electrolytic 10 $\mu$ F, $\pm$ 20%, 25V, Electrolytic
Q1	<b>TRANSISTOR</b> 5614-669(C)	2SD669(C) or 2SD669(D)
$\Delta$ D1 $\Delta$ D2 D3	<b>DIODES</b> 5685-1F 5632-1SR35-10 5635-RD11EB2	Bridge Silicon, S1WB10 1SR35-10 Zener, RD11EB2
$\Delta$ FU1 $\Delta$ " $\Delta$ P3, 4 $\Delta$ J3/4	<b>MISCELLANEOUS</b> 5732-801031 5732-31102 4442-2 D443-T55CA 4472-0131 2132-7048	Fuse, 800mA, 125V (for U.S.A. & Canada models) Fuse, T315mA, 250V (for General model) Connector (General model only) Connector with lead Wire (General model only) Fuse Holder (X2) Spacer, R1
<b>PCB-3 CONTROL SWITCH P.C. BOARD</b>		
D401 SW401, 402, 403	5637-GL5HD10 4431-03067153	L.E.D., GL5HD10, Quartz Lock Indicator Push Switch, 33/45 Speed Selector, Quartz Lock
<b>PCB-4 LED P.C. BOARD</b>		
C705 D701, 702	5345-476C0951 5637-TLR108A	Capacitor, 47 $\mu$ F, $\pm$ 20%, 16V, Electrolytic L.E.D., TLR-108A
<b>PCB-5 PHOTO TRANSISTOR P.C. BOARD</b>		
Q701, 702	5621-PT350F	Photo Transistor, PT350F
<b>PCB-6 CAPACITANCE TRIM SELECTOR P.C. BOARD</b>		
C701, 702 SW701	5359-2015851 4411-203712	Capacitor, 200pF, $\pm$ 5%, 100V, Polypropylene Rotary Switch, Capacitance Trim Selector
<b>PCB-7 LIFT &amp; CUT SWITCHES P.C. BOARD</b>		
SW404, 405	4431-02047171	Push Switch, Cut, Lift
<b>PCB-8 SPEED CONTROL P.C. BOARD</b>		
VR401	5113-10371136	Variable Resistor, 10k $\Omega$ B, Speed Control
<b>PCB-9 TRANSISTOR P.C. BOARD</b>		
Q106	5613-3297(Y)	Transistor, 2SC3297(Y) or 2SC3297(O)
<b>PCB-10 RELAY P.C. BOARD</b>		
C703, 704	5359-2015851	Capacitor, 200pF, $\pm$ 5%, 100V, Polypropylene

**PACKAGE**

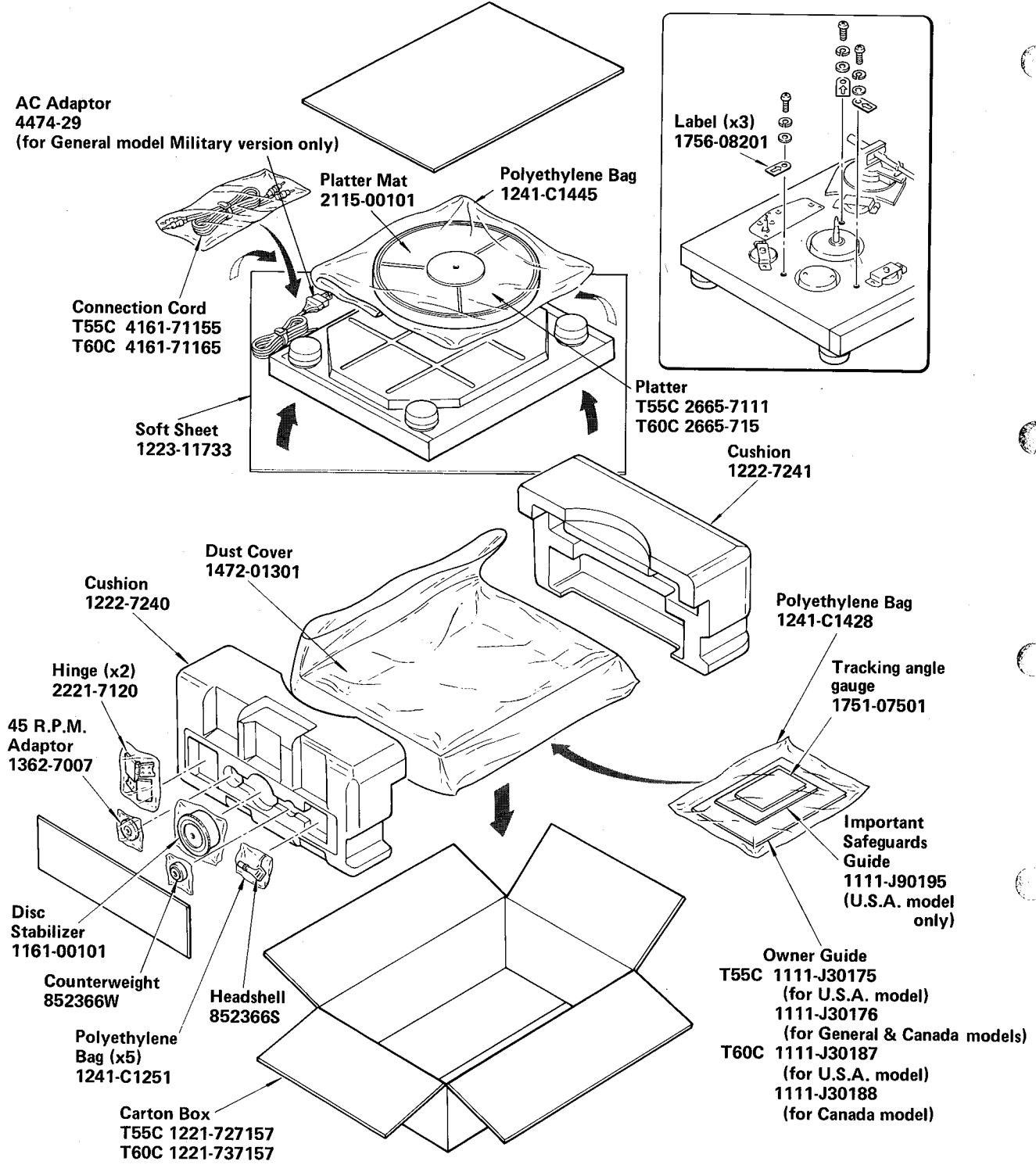

SCHEMATIC DIAGRAM

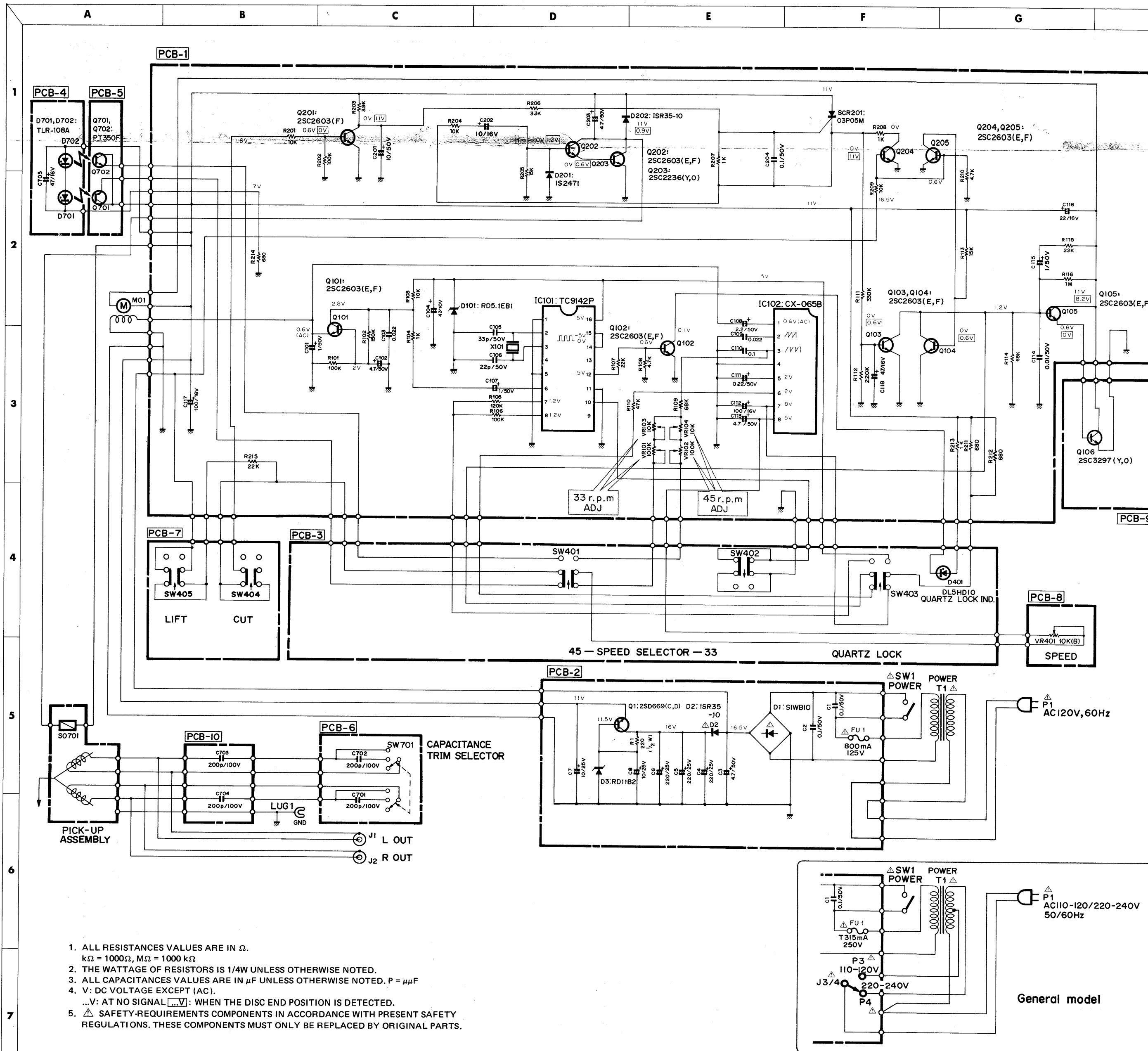

IC FUNCTIONAL BLOCK DIAGRAM

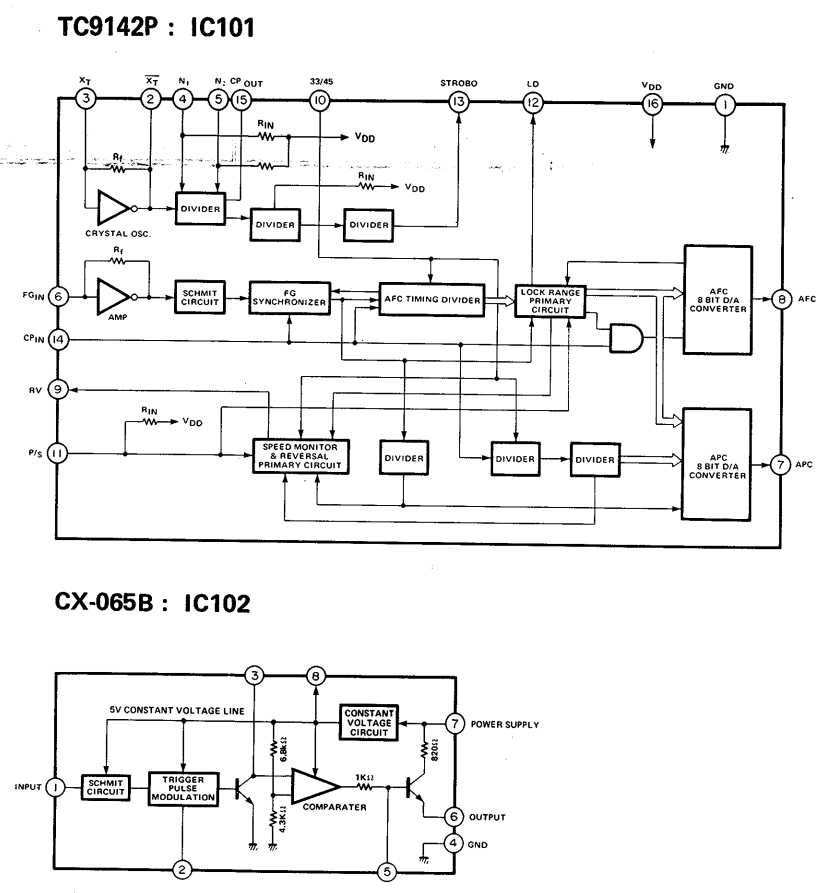

BLOCK DIAGRAM

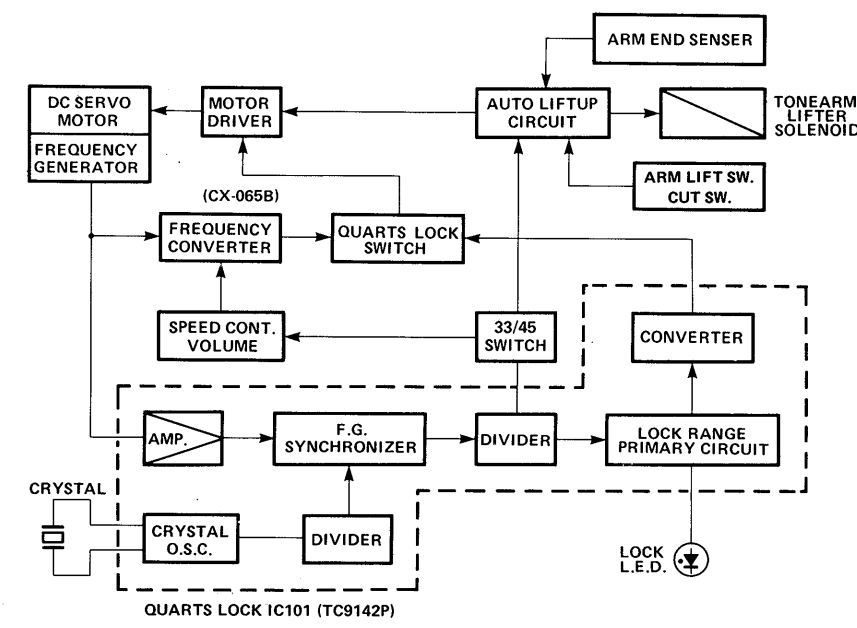

- ALL RESISTANCES VALUES ARE IN  $\Omega$ .  
k $\Omega$  = 1000 $\Omega$ , M $\Omega$  = 1000 k $\Omega$
- THE WATTAGE OF RESISTORS IS 1/4W UNLESS OTHERWISE NOTED.
- ALL CAPACITANCES VALUES ARE IN  $\mu F$  UNLESS OTHERWISE NOTED. P =  $\mu\mu F$
- V: DC VOLTAGE EXCEPT (AC).  
...V: AT NO SIGNAL [V]: WHEN THE DISC END POSITION IS DETECTED.
- SAFETY-REQUIREMENTS COMPONENTS IN ACCORDANCE WITH PRESENT SAFETY REGULATIONS. THESE COMPONENTS MUST ONLY BE REPLACED BY ORIGINAL PARTS.

# SCHEMATIC DIAGRAM

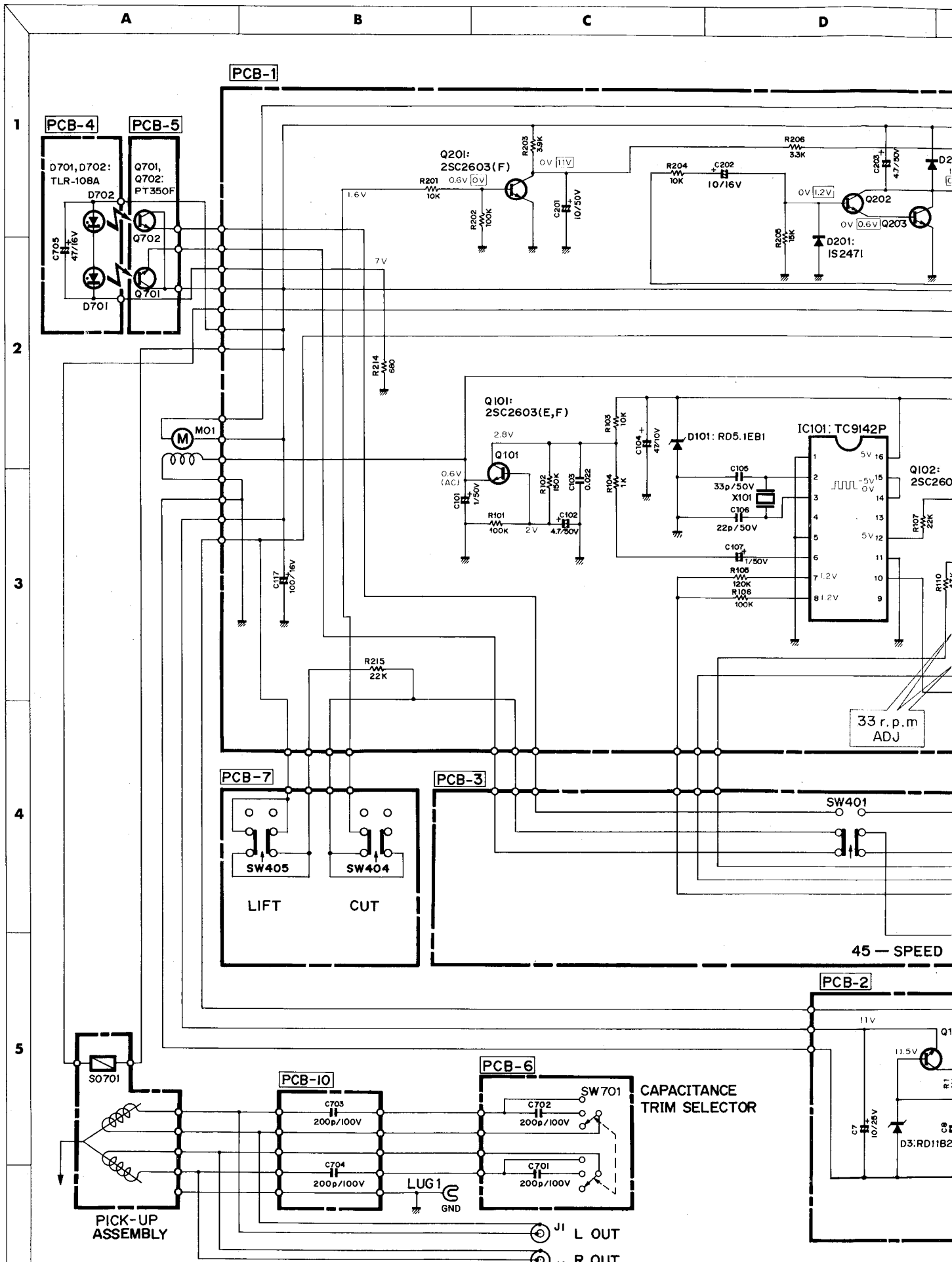



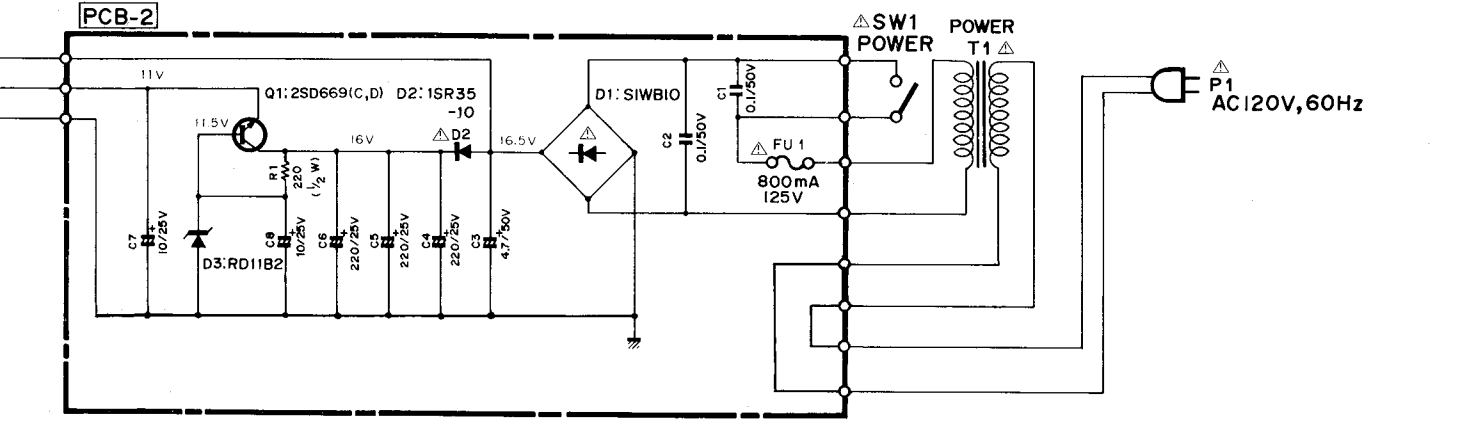
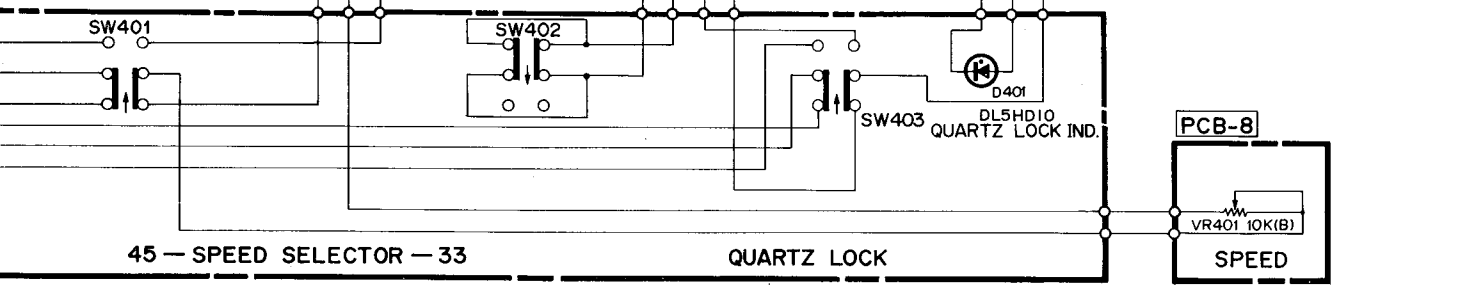
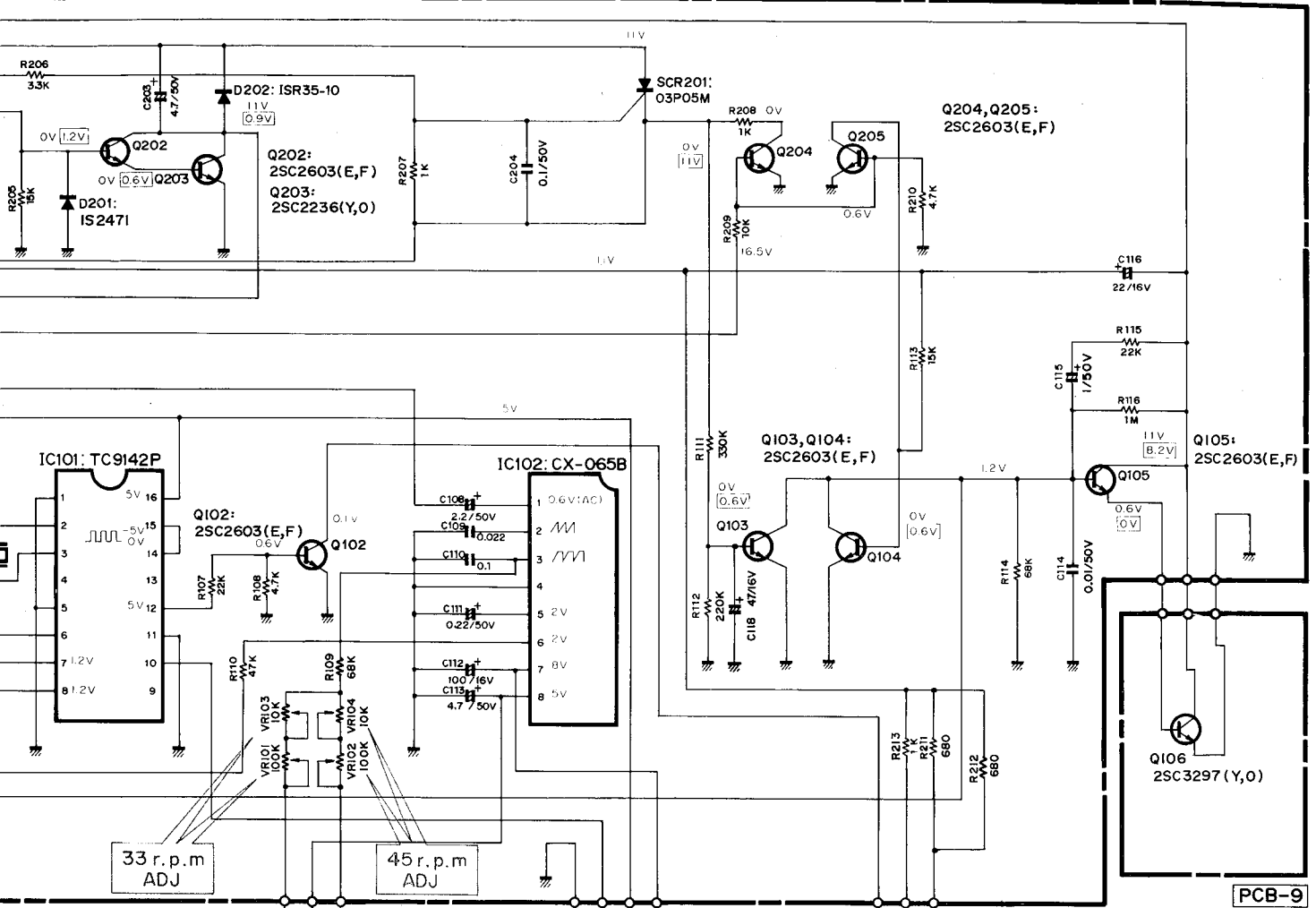

F G H I J

IC FUNCTIONAL BLOCK DIAGRAM

TC9142P : IC101

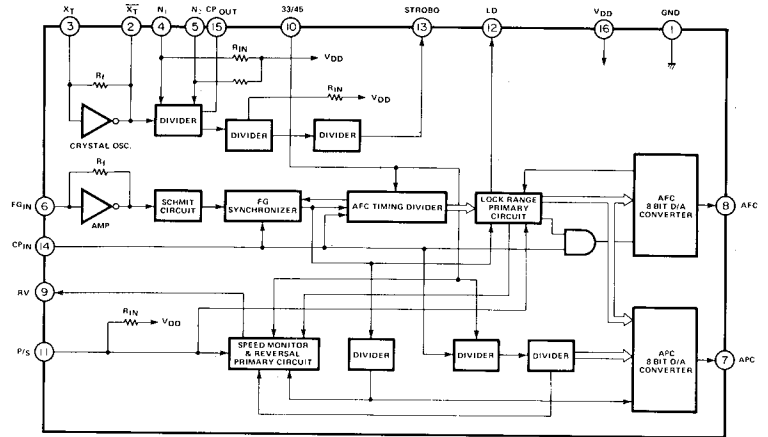

CX-065B : IC102

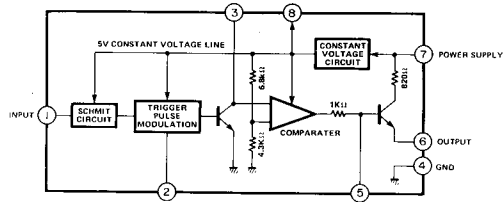

BLOCK DIAGRAM

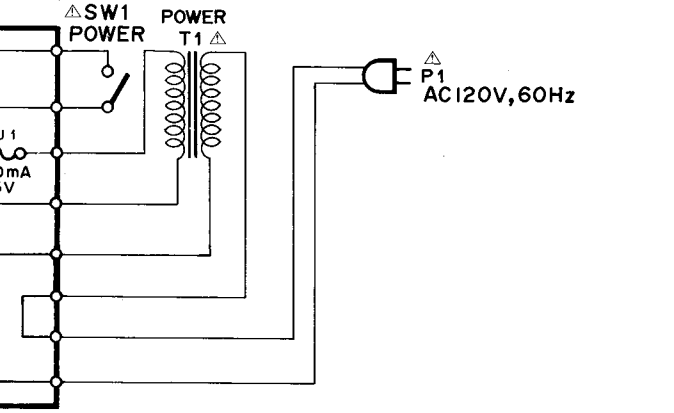
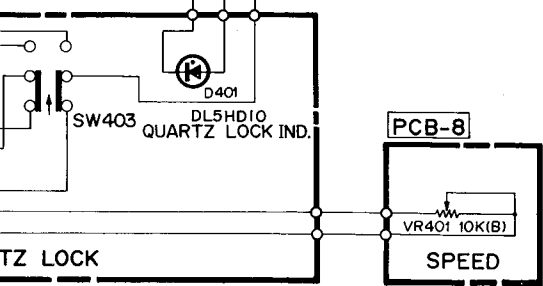
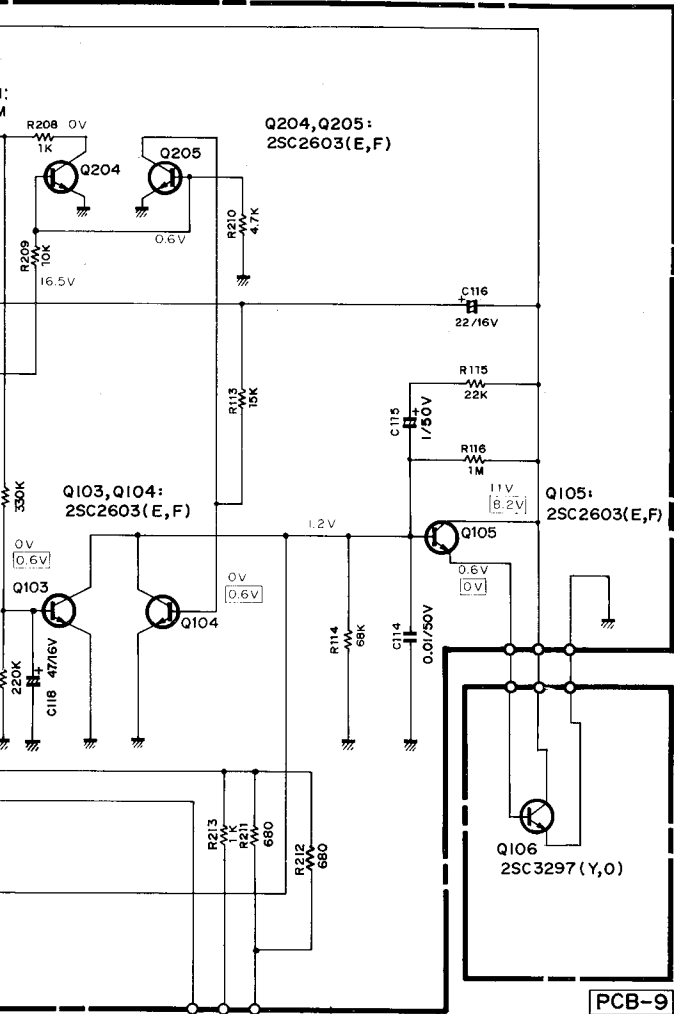
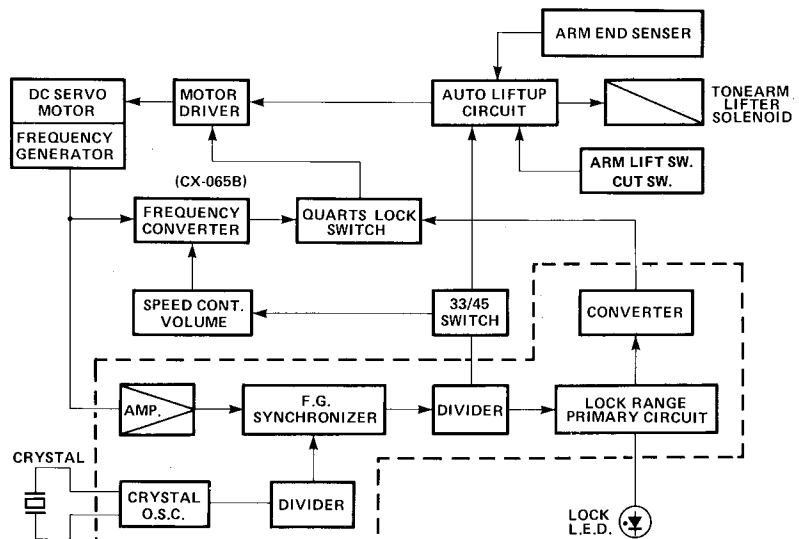

2  
3  
4  
5  
6  
7

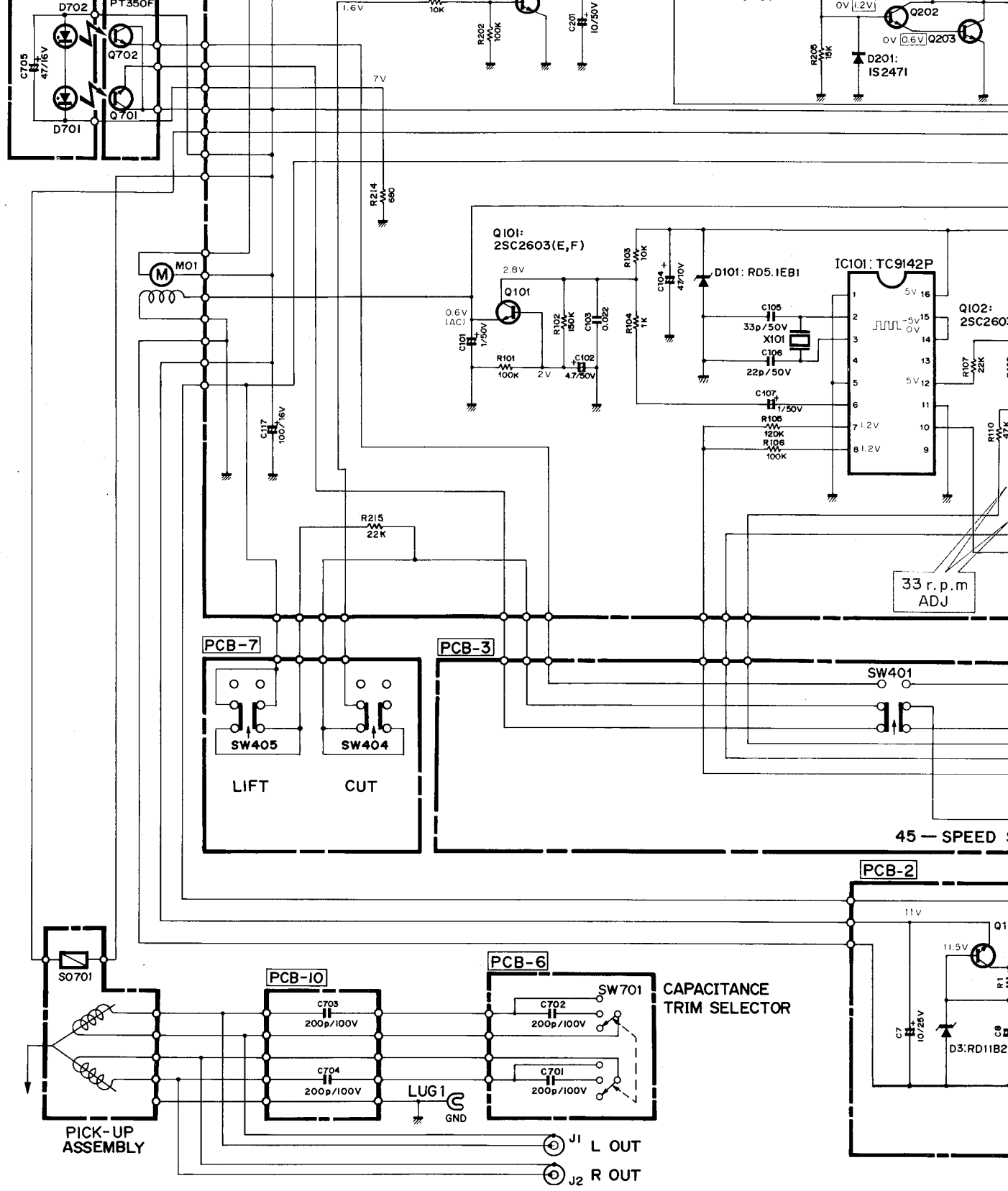

1. ALL RESISTANCES VALUES ARE IN  $\Omega$ .  
 $k\Omega = 1000\Omega$ ,  $M\Omega = 1000 k\Omega$
2. THE WATTAGE OF RESISTORS IS 1/4W UNLESS OTHERWISE NOTED.
3. ALL CAPACITANCES VALUES ARE IN  $\mu F$  UNLESS OTHERWISE NOTED.  $P = \mu\mu F$
4. V: DC VOLTAGE EXCEPT (AC).  
 $\dots V$ : AT NO SIGNAL  $\dots V$ : WHEN THE DISC END POSITION IS DETECTED.
5.  $\Delta$  SAFETY-REQUIREMENTS COMPONENTS IN ACCORDANCE WITH PRESENT SAFETY REGULATIONS. THESE COMPONENTS MUST ONLY BE REPLACED BY ORIGINAL PARTS.

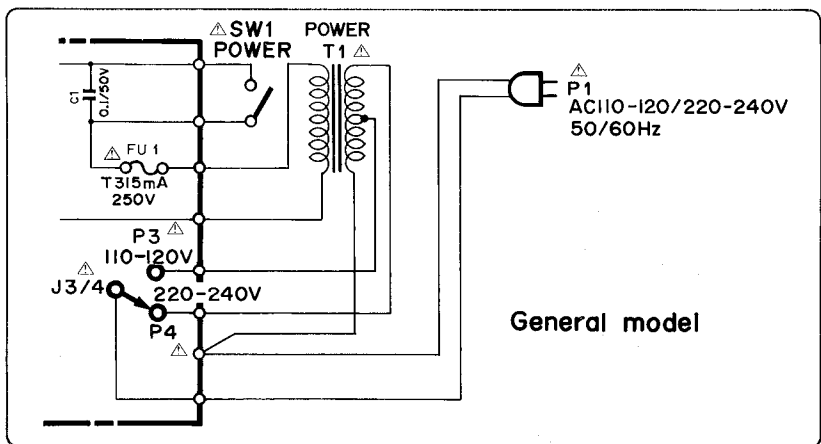
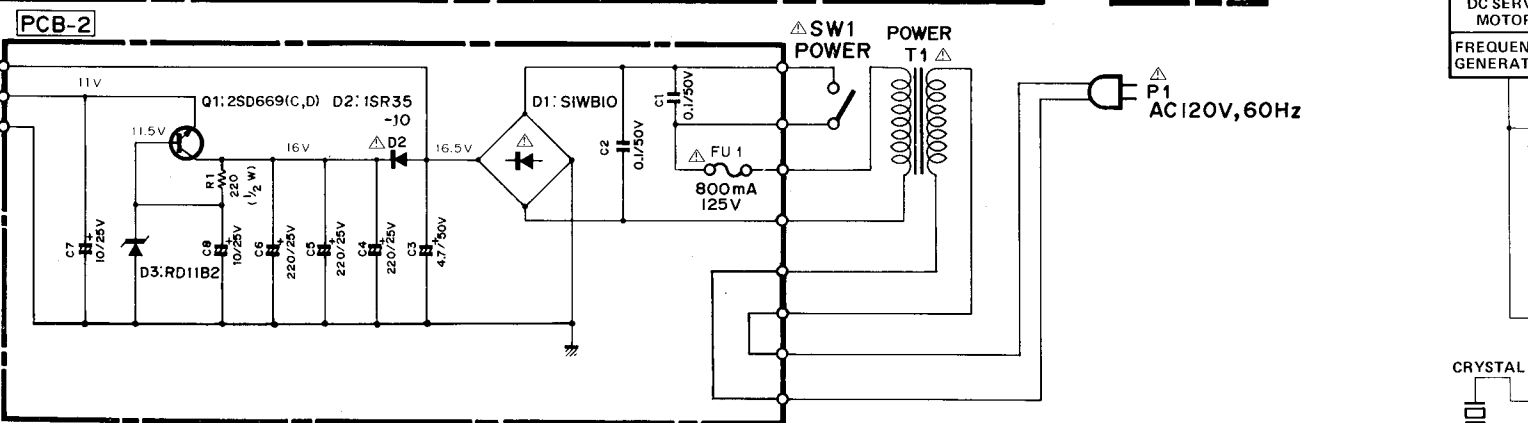
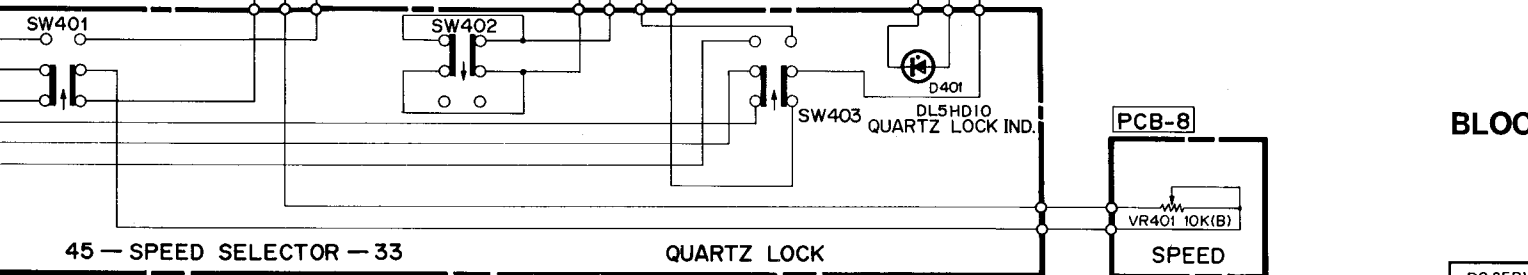
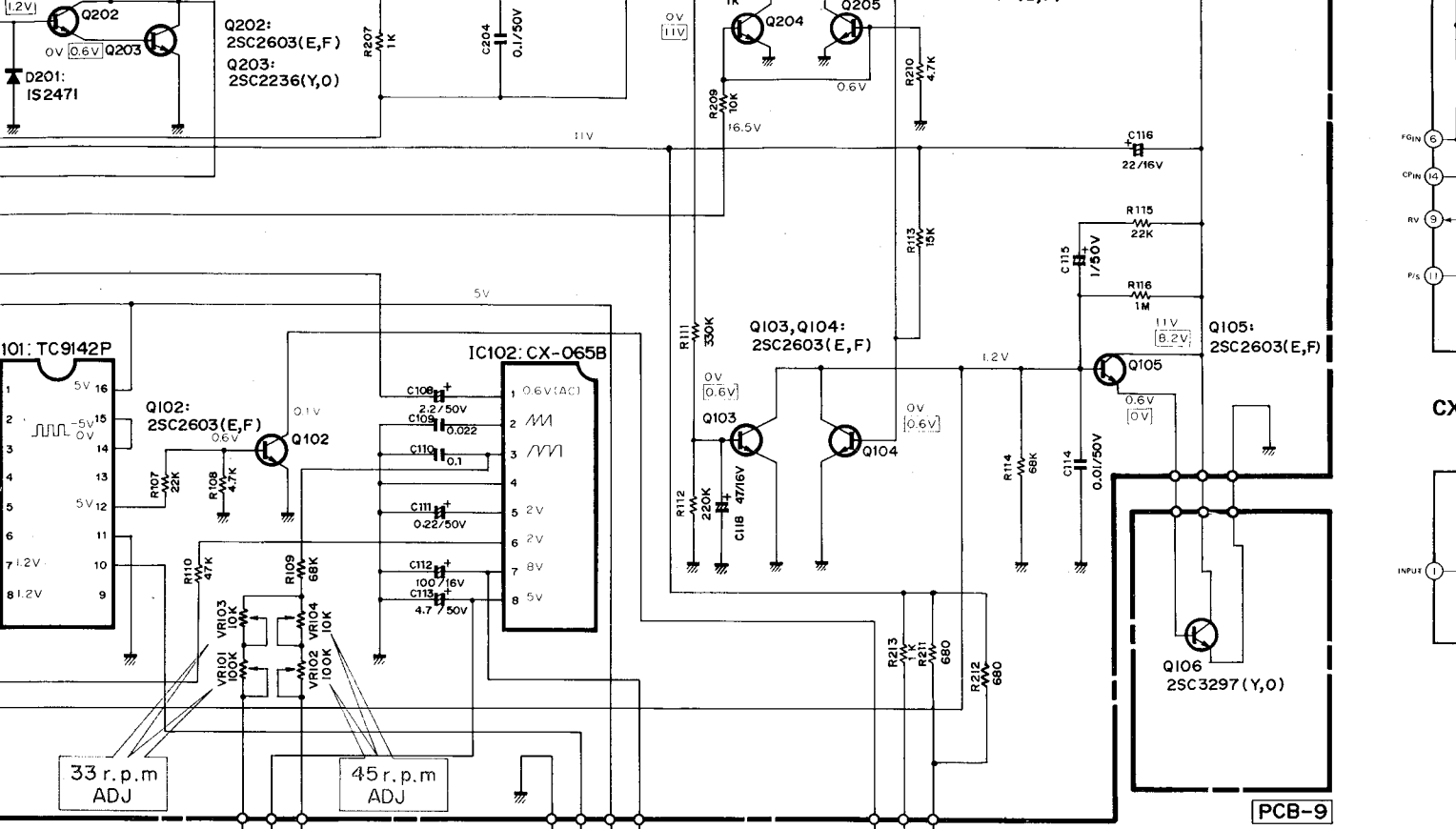

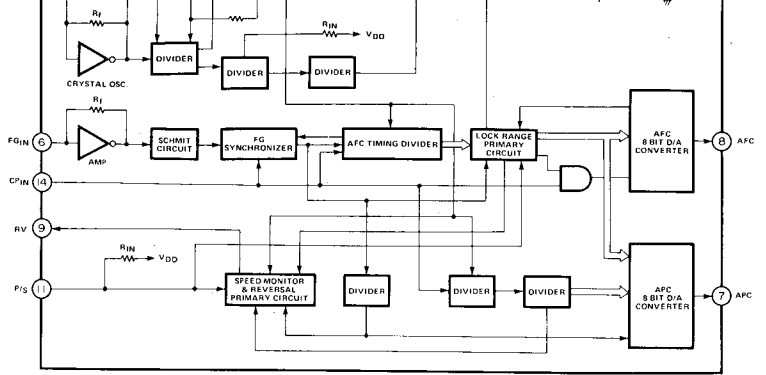
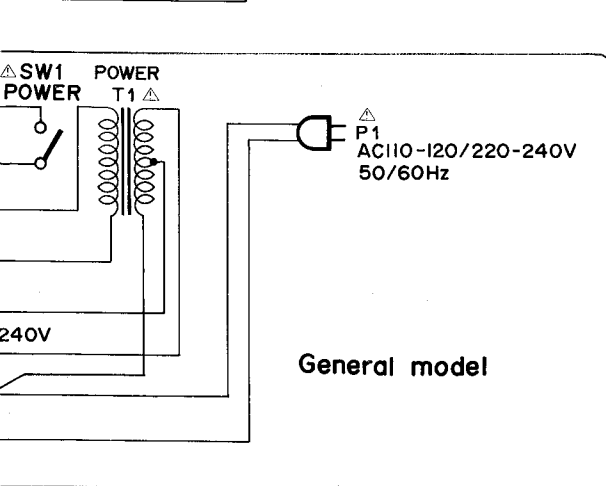
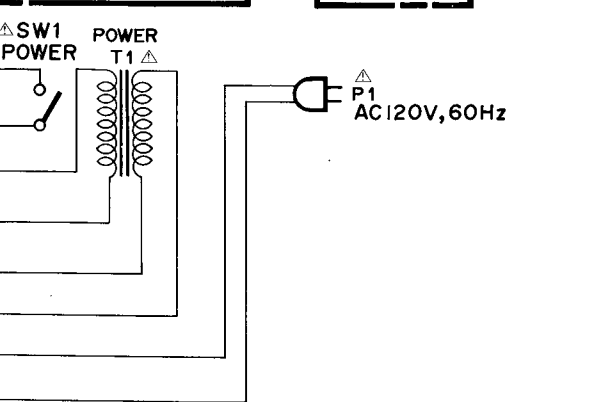
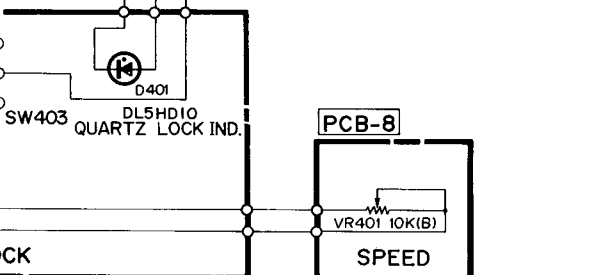
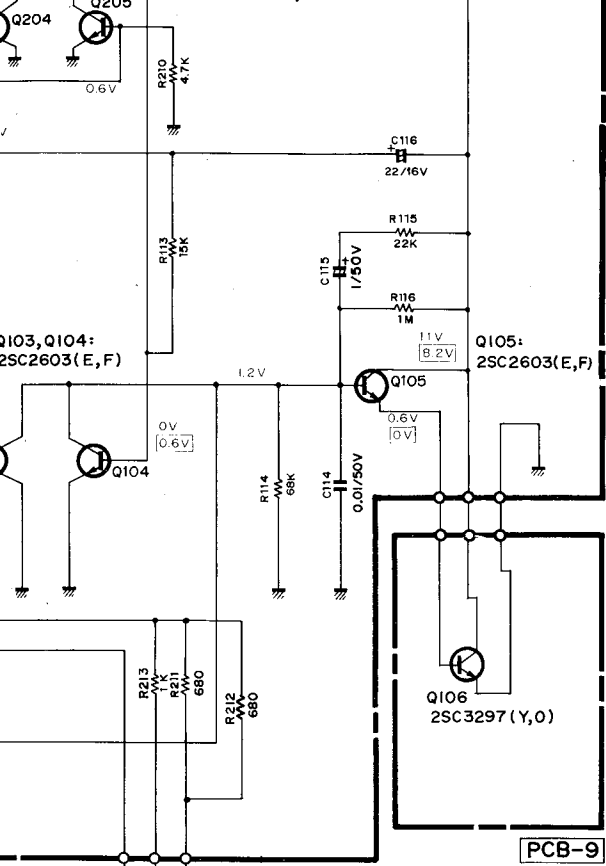

CX-065B : IC102

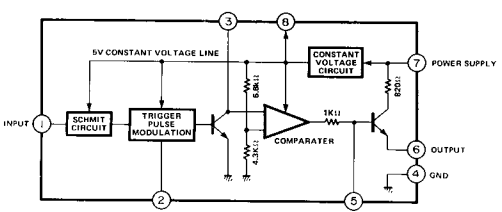

BLOCK DIAGRAM

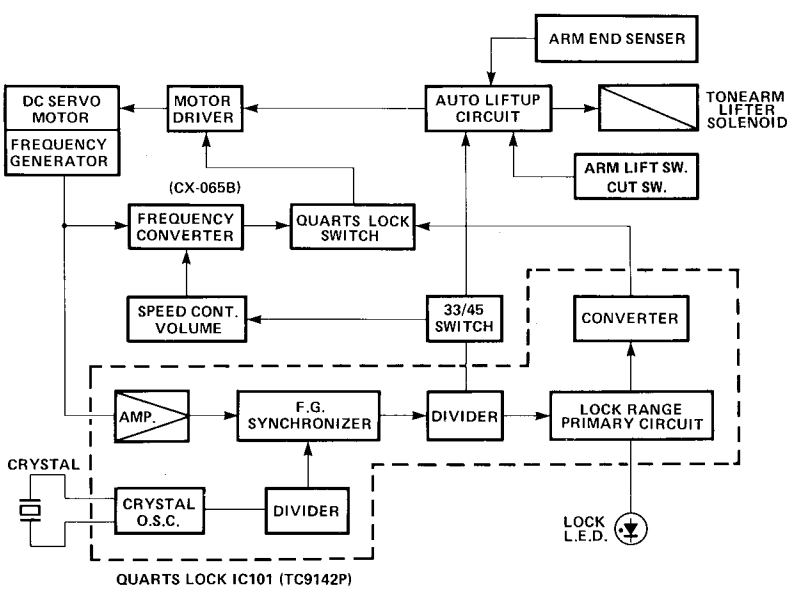

WIRING DIAGRAM

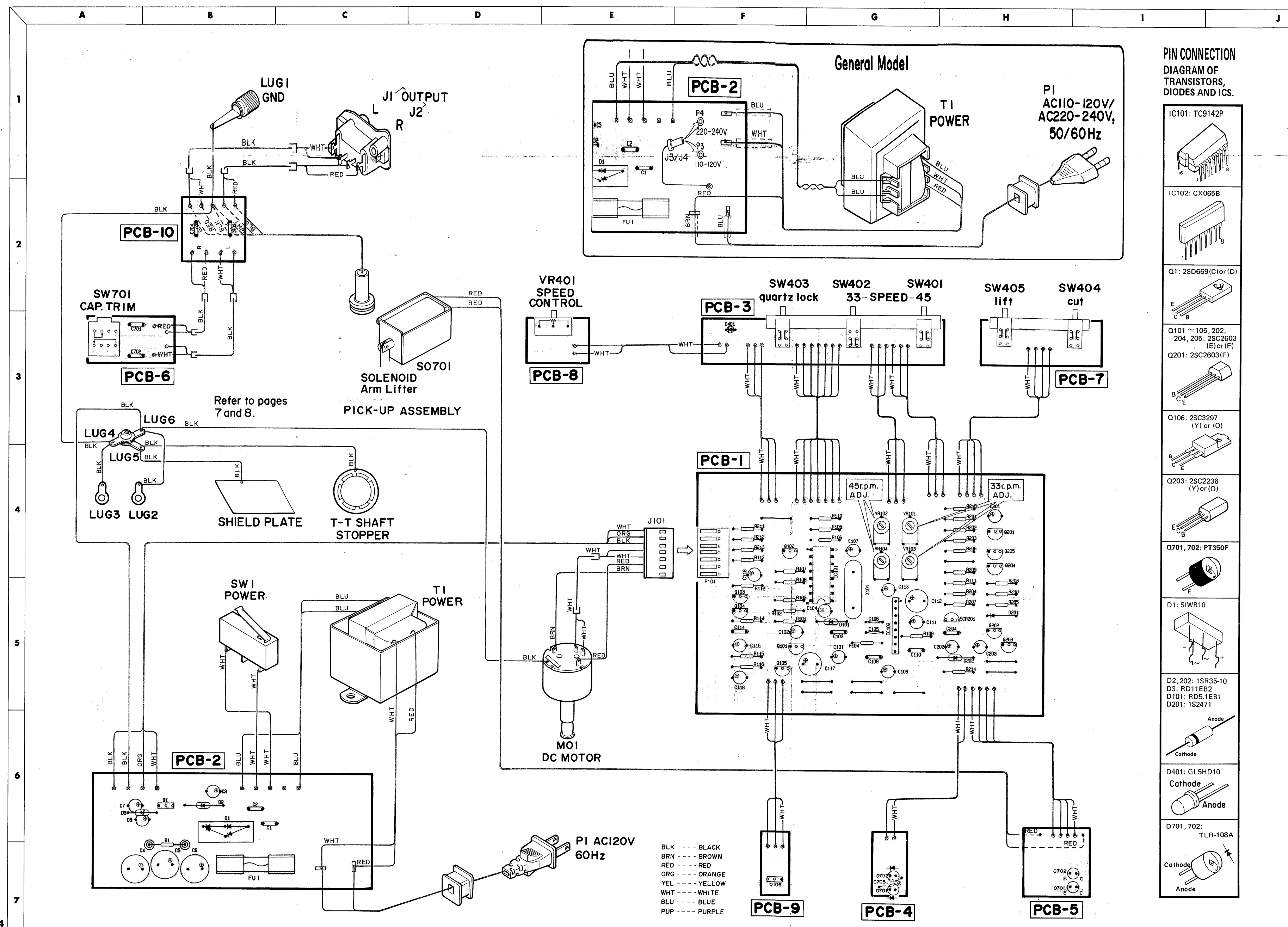

PIN CONNECTION DIAGRAM OF TRANSISTORS, DIODES AND ICs.

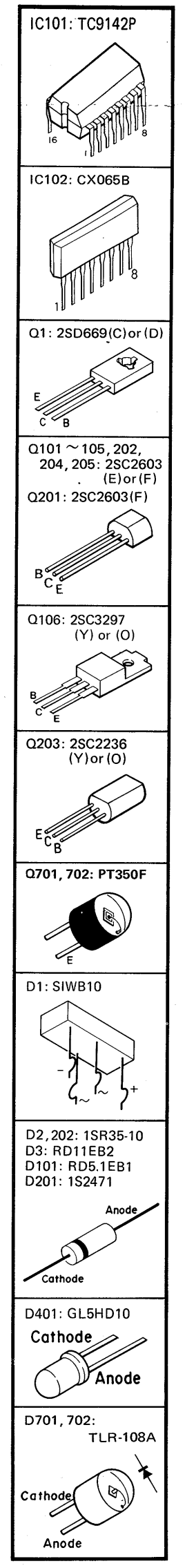

WIRING DIAGRAM

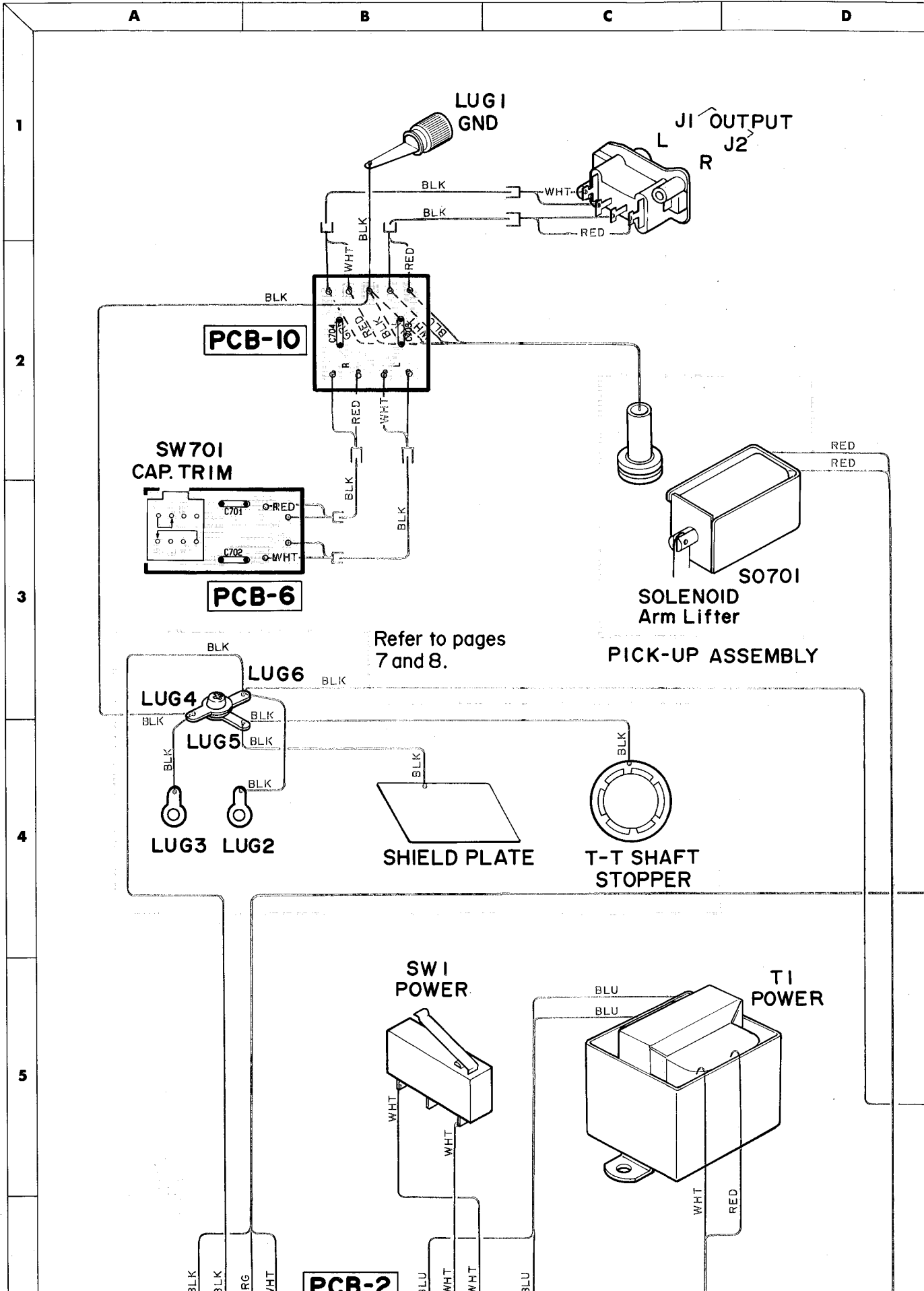

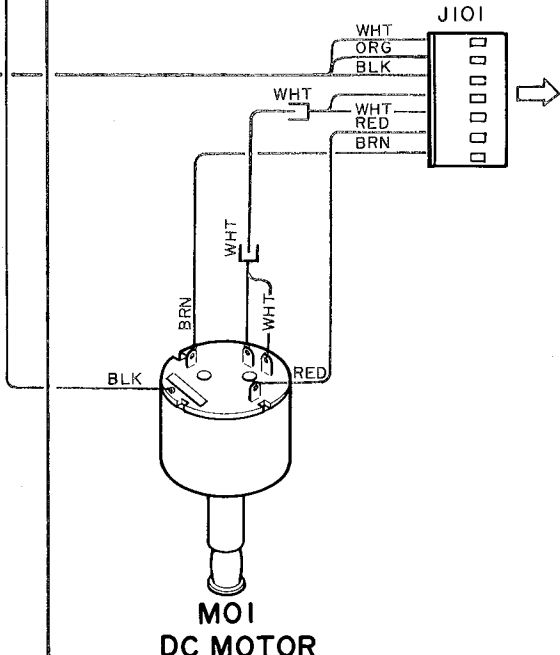
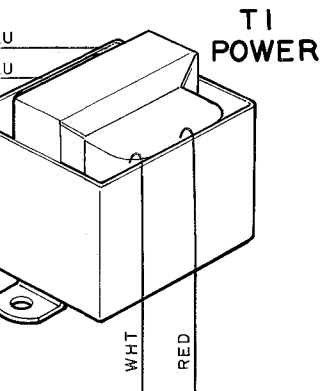
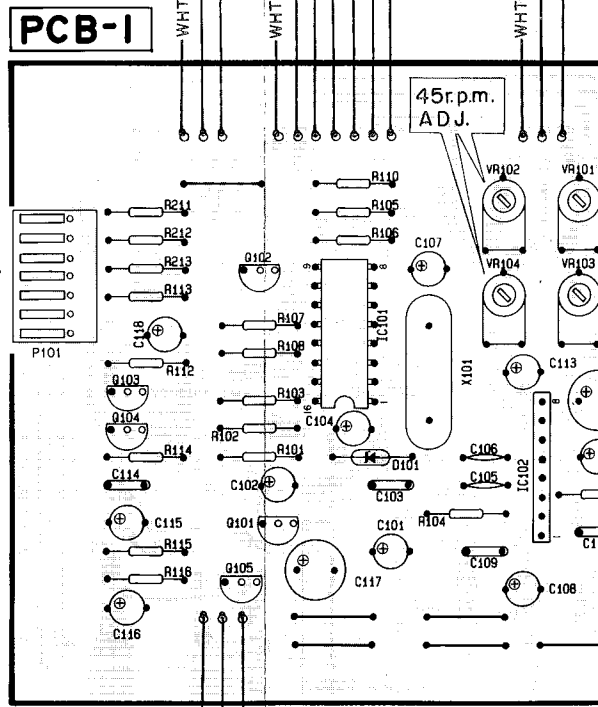
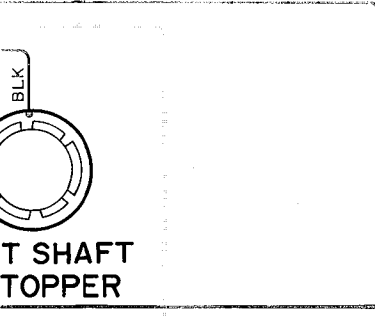
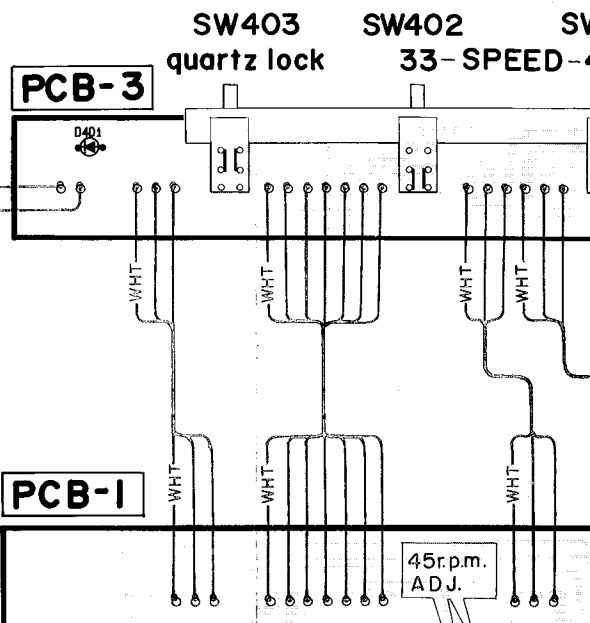
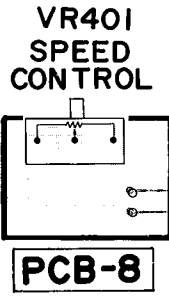
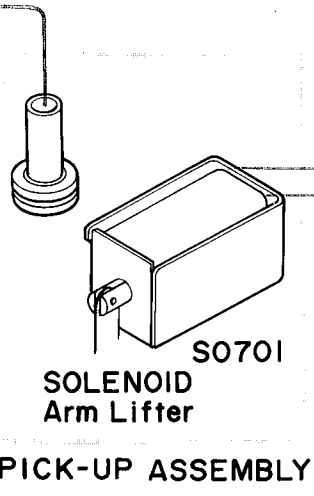
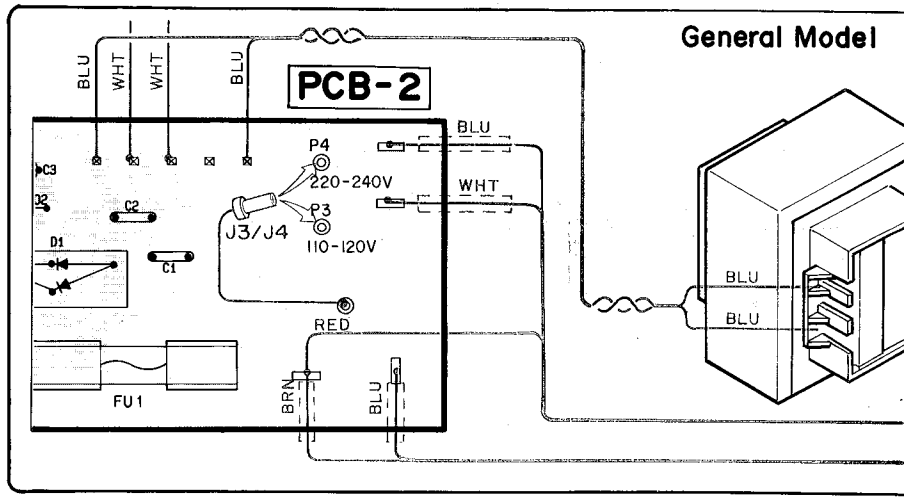
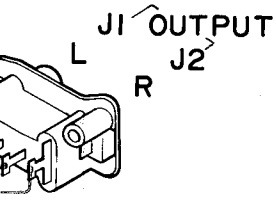



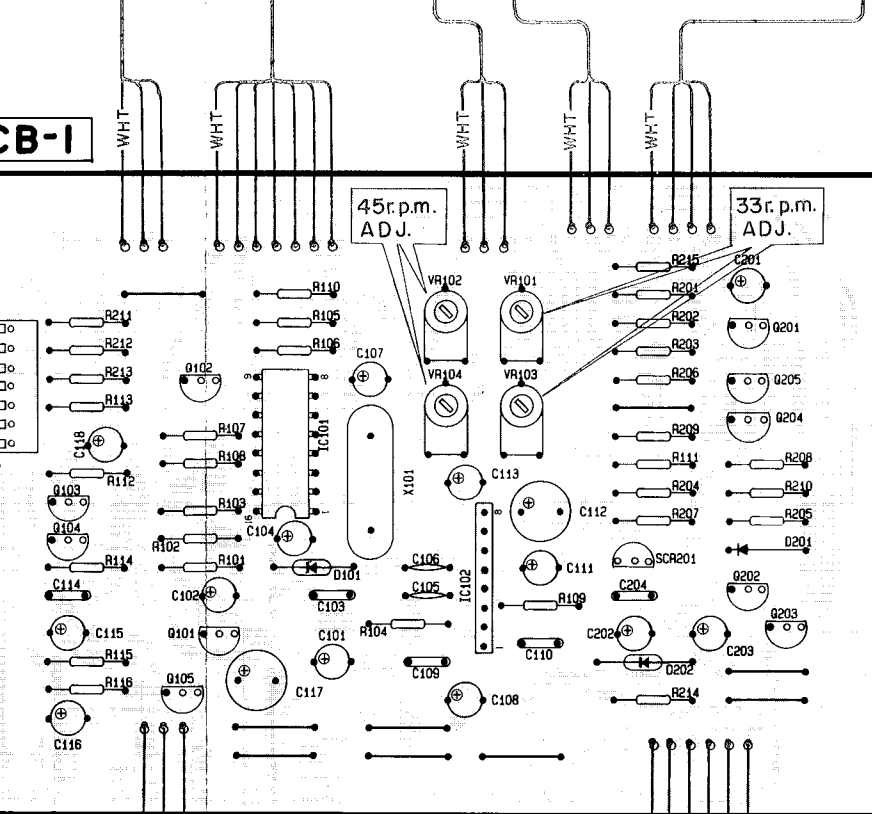
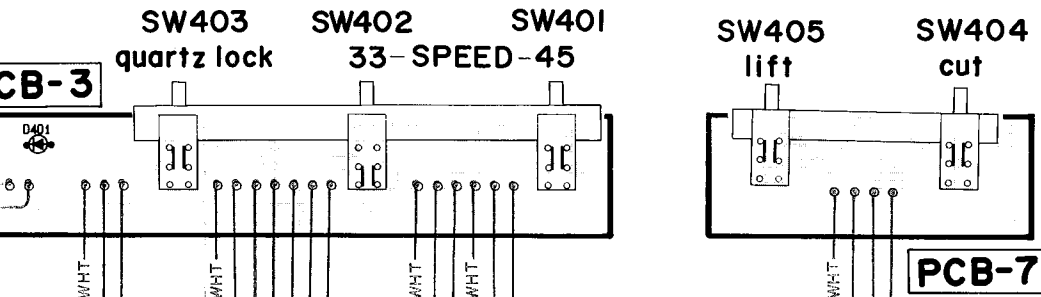
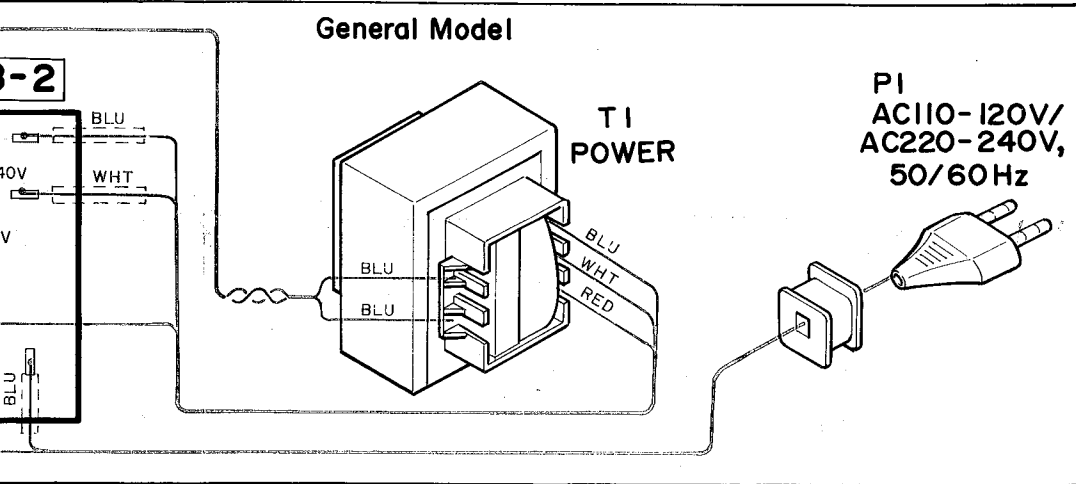

**PIN CONNECTION  
DIAGRAM OF  
TRANSISTORS,  
DIODES AND ICS.**

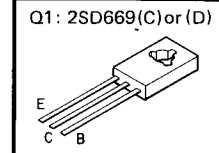
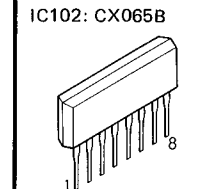
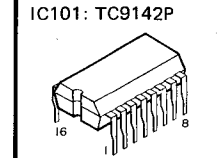

Q101 ~ 105, 202,  
204, 205: 2SC2603  
(E) or (F)

Q201: 2SC2603(F)

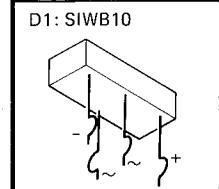
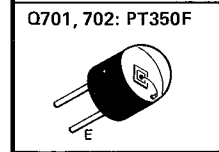
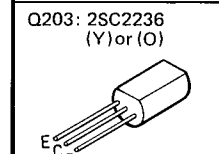
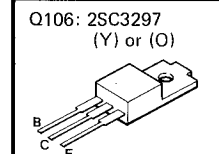
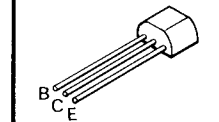

D2, 202: 1SR35-10  
D3: RD11EB2  
D101: RD5.1EB1  
D201: 1S2471

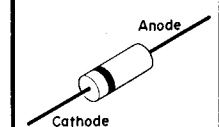

2

3

4

5

6

7

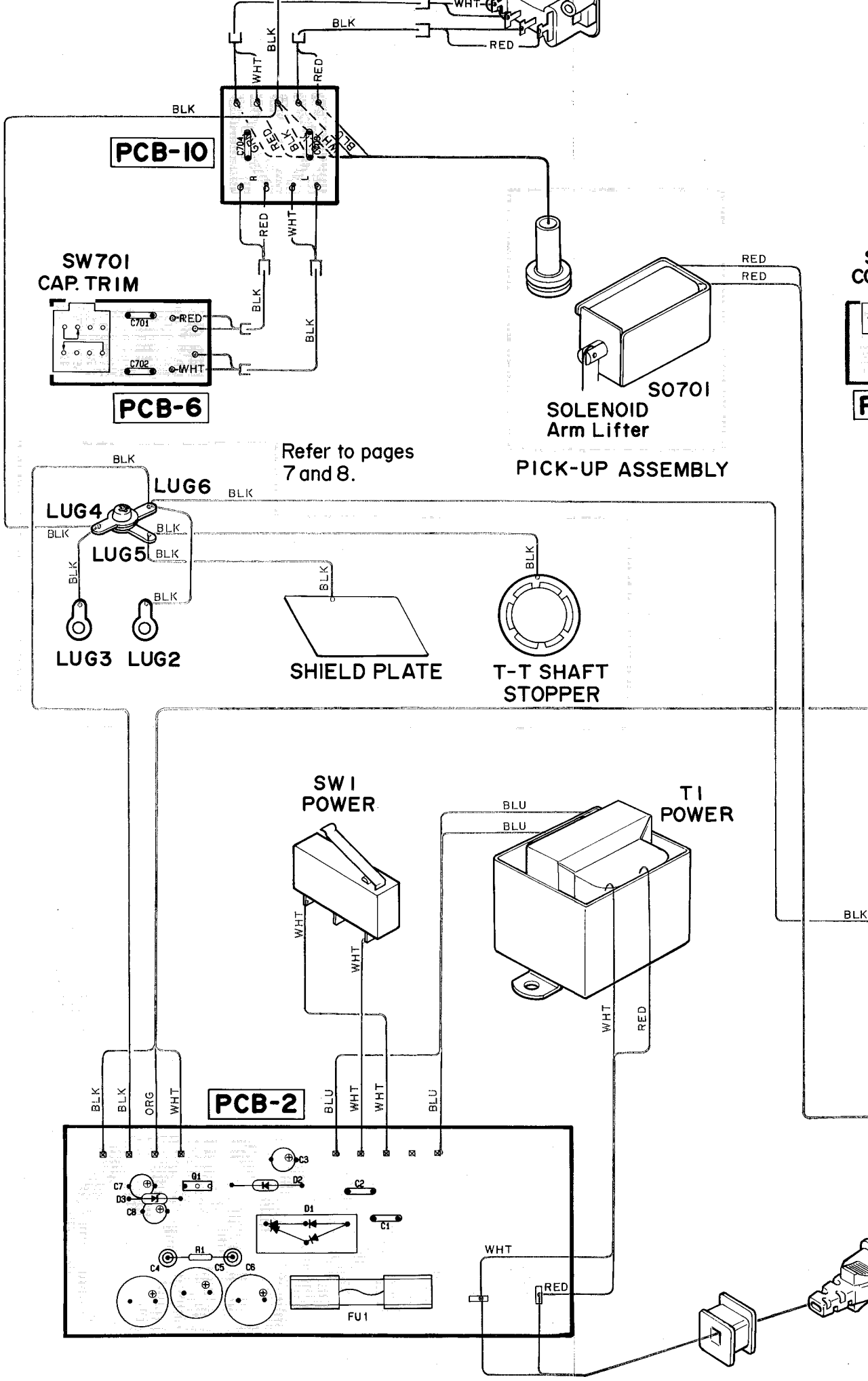

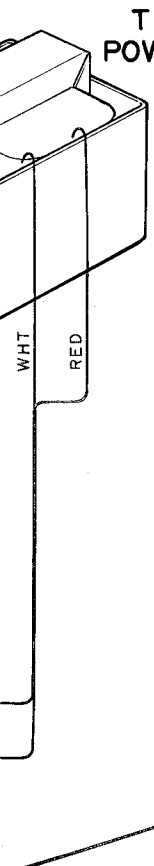
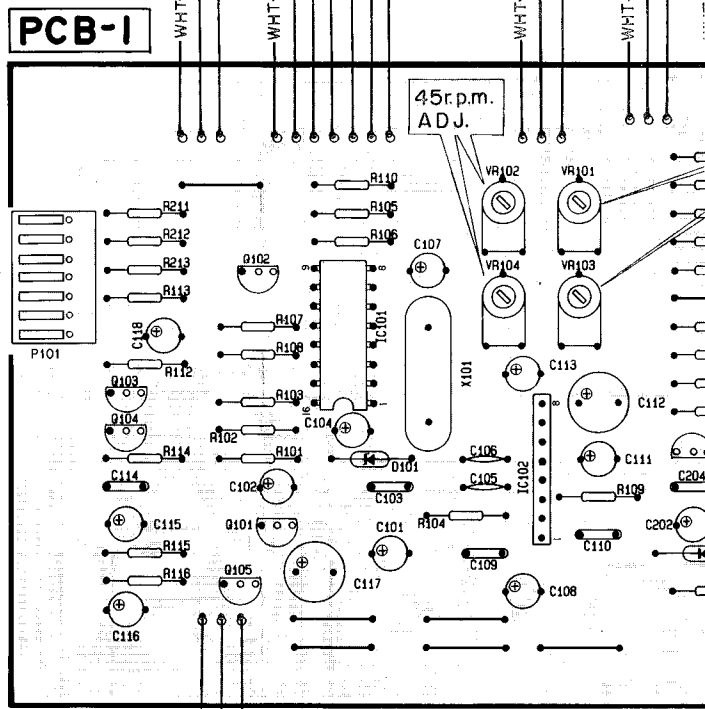
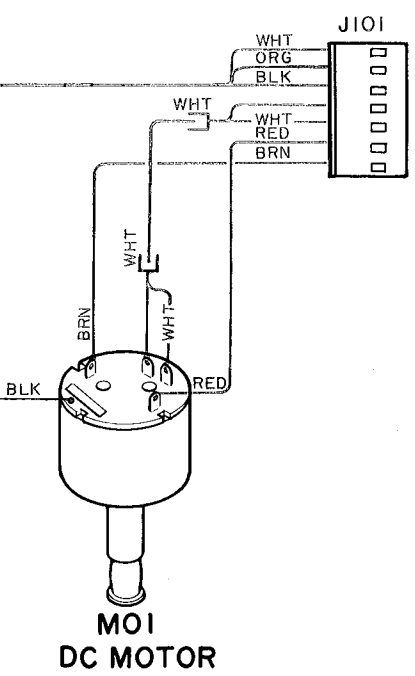
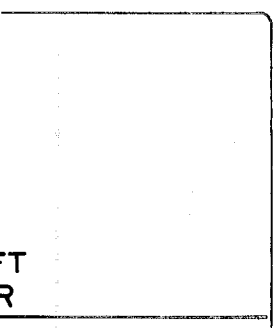
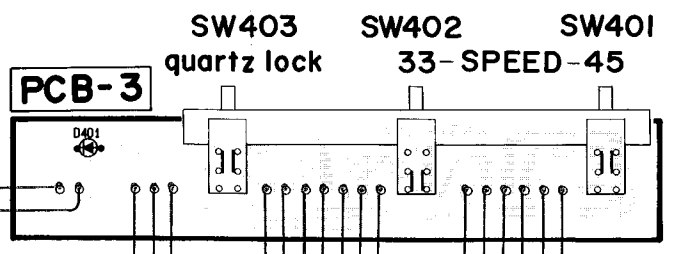
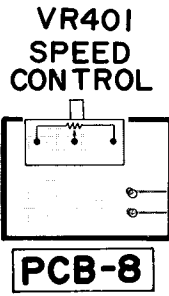
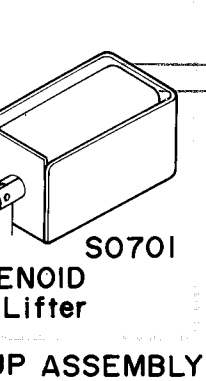
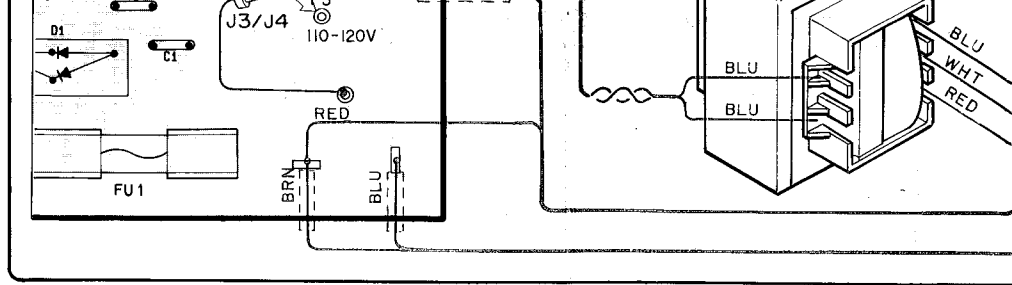

Refer to pages 7 and 8.

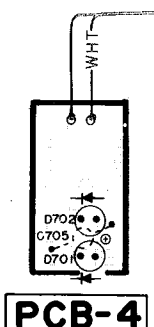
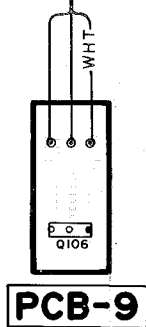

- BLK ---- BLACK
- BRN ---- BROWN
- RED ---- RED
- ORG ---- ORANGE
- YEL ---- YELLOW
- WHT ---- WHITE
- BLU ---- BLUE
- PUP ---- PURPLE

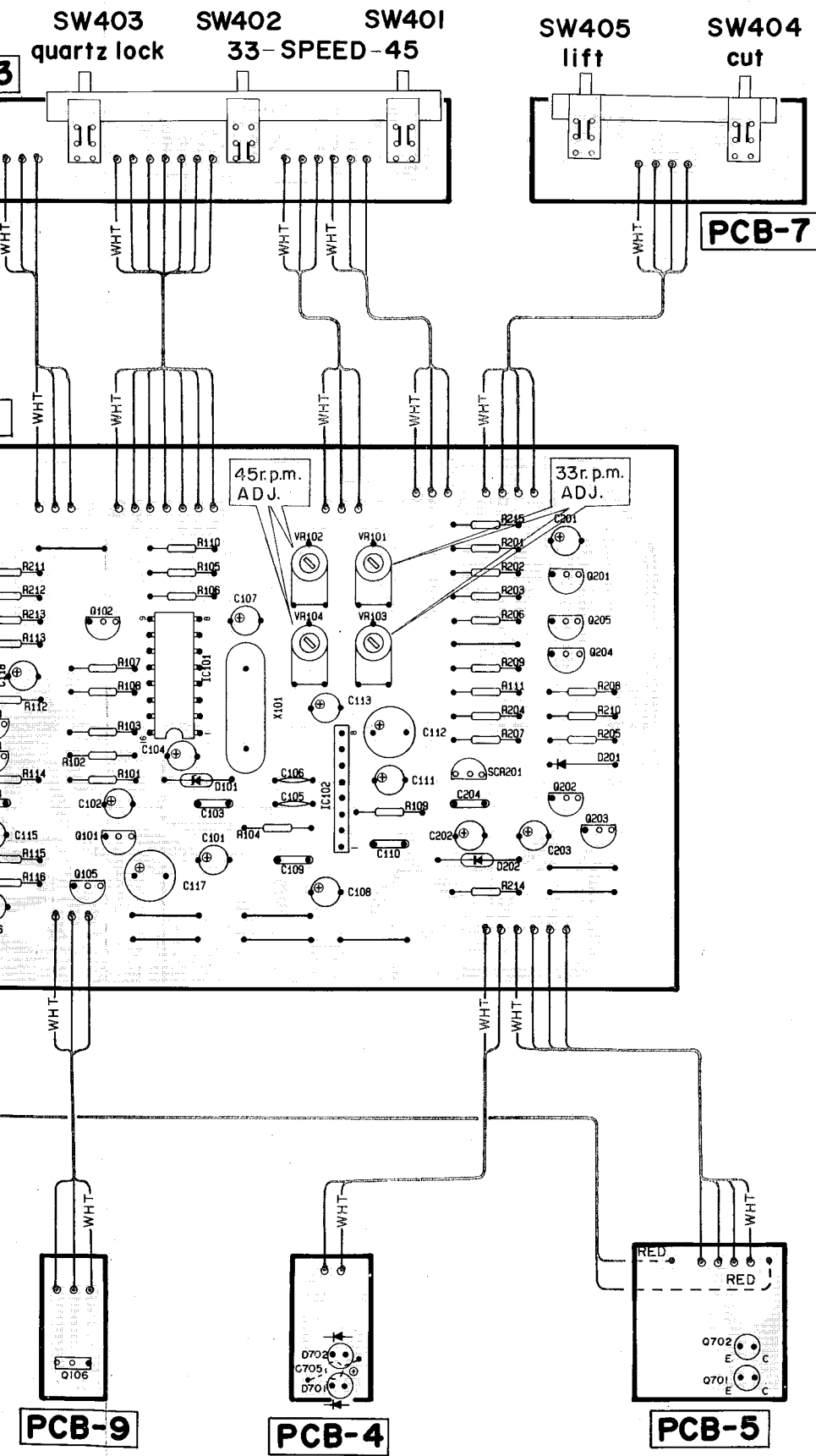
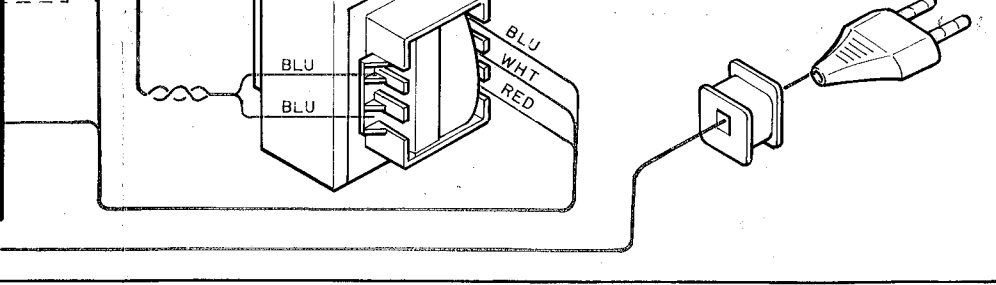

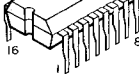
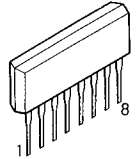
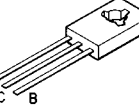
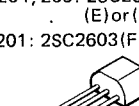
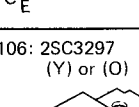
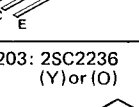
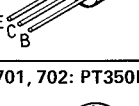
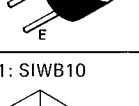

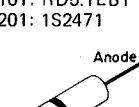
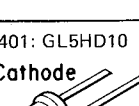
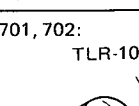
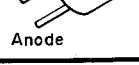
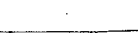
-   
IC102: CX065B
-   
Q1: 2SD669(C) or (D)
-   
Q101 ~ 105, 202, 204, 205: 2SC2603 (E) or (F)
-   
Q201: 2SC2603(F)
-   
Q106: 2SC3297 (Y) or (O)
-   
Q203: 2SC2236 (Y) or (O)
-   
Q701, 702: PT350F
-   
D1: SIWB10
-   
D2, 202: 1SR35-10
-   
D3: RD11EB2
-   
D101: RD5.1EB1
-   
D201: 1S2471
-   
D401: GL5HD10
-   
D701, 702: TLR-108A